

KATflow 100 Standard Clamp-On Ultrasonic Flow Transmitter

SMALL. SIMPLE. STURDY.

The KATflow 100 is a compact clamp-on ultrasonic flow transmitter with a robust and practical design for permanent installation and flow measurement on single pipes. The instrument offers a cost-effective option owing to its simplified specification and the availability of a

range of transducer types. The varied functionality and simple operation of the KATflow 100 make it the perfect product for large projects and customer specific solutions.



THE TECHNOLOGY BEHIND THE MEASUREMENT

The KATflow non-invasive flowmeters work on the transit time ultrasonic principle. This involves sending and receiving ultrasonic pulses from a pair of sensors and examining the time difference in the signal. Katronic uses clamp-on transducers that are mounted externally on the surface of the pipe and which generate pulses that pass through the pipe wall. The flowing liquid within causes time differences in the ultrasonic signals, which are then evaluated by the flowmeter to produce an accurate flow measurement. The key principle of the method applied is that sound waves travelling with the flow will move faster than those travelling against it. The difference in the transit

time of these signals is proportional to the flow velocity of the liquid and consequently the flow rate.

Since elements such as flow profile, type of liquid and pipe material will have an effect on the measurement, the flowmeter compensates for and adapts to changes in the medium in order to provide reliable results. The instruments can be used in a variety of locations, from measurements on submarines to installations on systems destined for use in space, and on process fluids as different as purified water in the pharmaceutical sector and toxic chemical effluent. The flowmeters will operate on various pipe materials and diameters over a range of 10 mm to 6,500 mm.

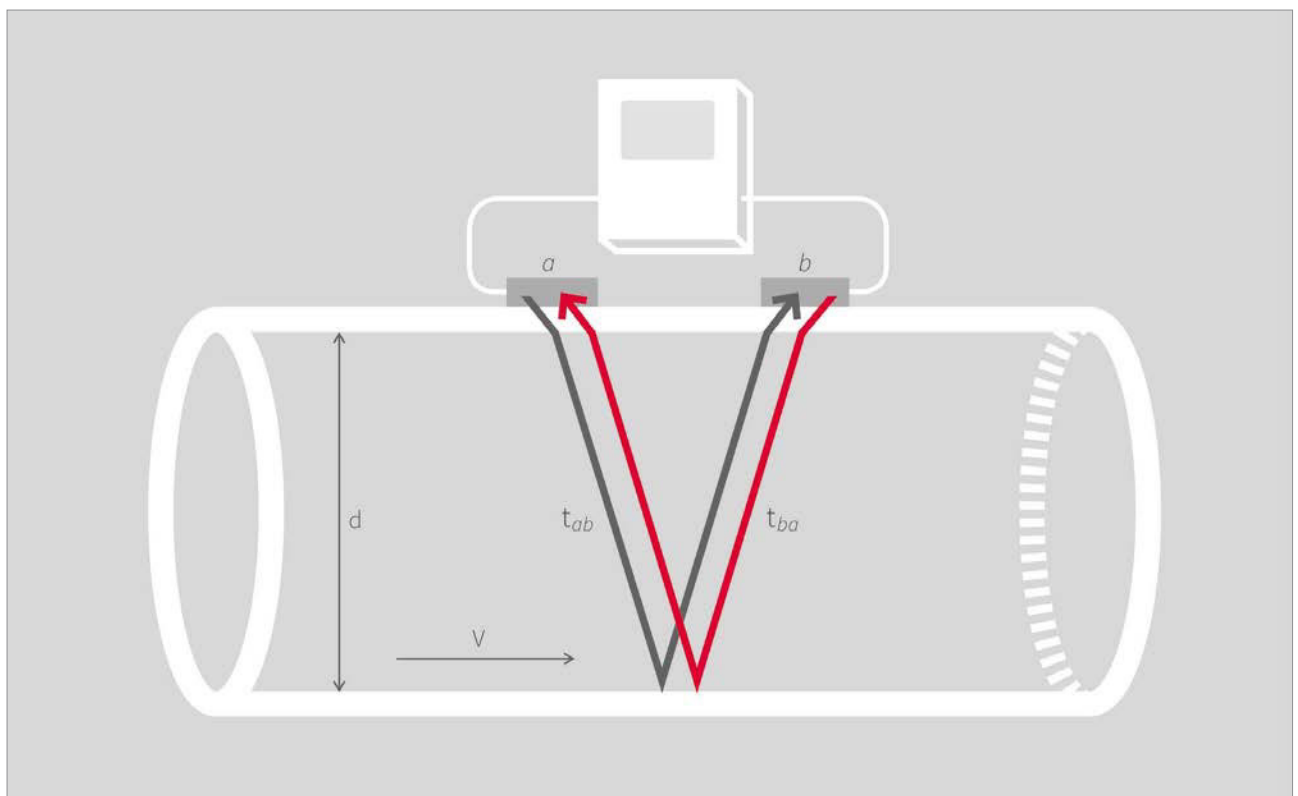

Sensors a and b work alternately to send and receive ultrasonic pulses. The sound waves travelling with the flow move faster than those travelling against it.

SPECIFICATION

- Pipe diameter range 10 mm to 3,000 mm
- Temperature range for sensors -30 °C to +80 °C (-22 °F to +17
- Weight 750 g
- Robust IP 66 aluminium enclosure
- Sturdy unit with LCD display and five-key keypad
- Wall or pipe mounted

FEATURES

- Low cost of ownership
- Process outputs including RS 485, Modbus RTU and HART* compatible output
- PT100 inputs for heat quantity (thermal energy) measurement
- Bi-directional measurement with totaliser function
- Innovative installation wizard for quick and intuitive programming
- Configuration can be changed to suit customer requirements

ACCESSORIES

- Optional blind transmitters supplied pre-configured or with external programming tool
- Available with special "P" transducers for simple applications
- Optional PT100 sensors or analogue temperature inputs for heat quantity measurement and temperature compensation

APPLICATIONS

- Water and wastewater measurements
- Replacement of electromagnetic flowmeters
- Monitoring and controlling of Heating, Ventilation and Air Conditioning (HVAC) systems
- Cost-effective solution for large scale projects
- Automated process control
- Shipping applications



TRANSMITTER

Performance

Measurement principle	Ultrasonic transit-time difference
Flow velocity range	0.01 ... 25 m/s
Resolution	0.25 mm/s
Repeatability	0.15 % of measured value, ± 0.015 m/s
Accuracy	Volume flow: $\pm 1 \dots 3$ % of measured value depending on application ± 0.5 % of measured value with process calibration Flow velocity (mean): ± 0.5 % of measured value
Turn down ratio	1/100 (equivalent to 0.25 ... 25 m/s)
Measurement rate	100 Hz
Response time	1 s (standard), 90 ms (optional)
Damping of displayed value	0 ... 99 s (selectable by user)
Gaseous and solid content of liquid media	< 10 % of volume

Images

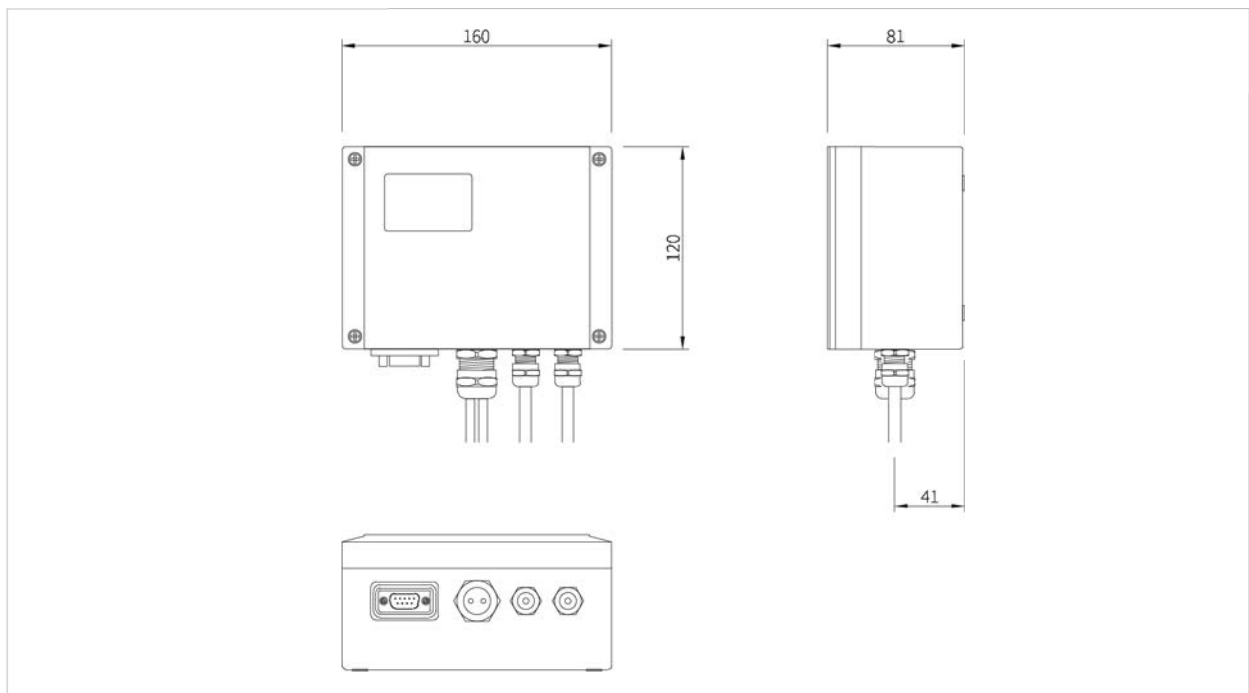

KATflow 100 (dimensions in mm)

General

Enclosure type	Wall mounted, optional pipe stands and brackets available
Degree of protection	IP 66 according to EN 60529
Operating temperature	-10 ... +60 °C (+14 ... +140 °F)
Housing material	Die-cast aluminium
Measurement channels	1
Power supply	100 ... 240 V AC, 50/60 Hz 9 ... 36 V DC Special solutions (e.g. solar panel, battery) on request
Display	LCD graphic display, 128 x 64 dots, backlit
Dimensions	120 (h) x 160 (w) x 81 (d) mm (without cable glands)
Weight	Approx. 750 g
Power consumption	<5W
Operating languages	English, French, German, Dutch, Spanish, Italian, Russian, Czech, Turkish, Romanian (others on request)

Communication

Type	RS 232 (used for external programming and data transfer), USB cable (optional), RS 485 or Modbus RTU (optional)
Transmitted data	Measured and totalised value, parameter set and configuration, logged data

Images



KATflow 100 with open enclosure



KATflow 100 in operation

KATdata+ software

Functionality	Download of measured values/parameter sets, graphical presentation, list format, export to third party software, online transfer of measured data
Operating systems	Windows 8, 7, Vista, XP, NT, 2000 Linux

Quantity and units of measurement

Volumetric flow rate	m ³ /h, m ³ /min, m ³ /s, l/h, l/min, l/s USgal/h (US gallons per hour), USgal/min, USgal/s bbl/d (barrels per day), bbl/h, bbl/min m/s, ft/s, inch/s
Flow velocity	
Mass flow rate	g/s, t/h, kg/h, kg/min
Volume	m ³ , l, gal (US gallons), bbl
Mass	g, kg, t
Heat flow	W, kW, MW (with heat quantity measurement option)
Heat quantity	J, kJ, kW/h (with heat quantity measurement option)
Temperature	°C (with heat quantity measurement option)

Process inputs (galvanically isolated)

Temperature	PT100 (clamp-on sensors), three-or four-wire circuit, measurement range: -30 ... +250 °C (-22 ... +482 °F), resolution: 0.1 K, accuracy: ±0.2 K
Current	0/4 ... 20 mA active or 0/4 ... 20 mA passive, U = 30 V, R _i = 50 Ω, accuracy: 0.1 % of measured value

Process outputs (galvanically isolated)

Current	0/4 ... 20 mA active/passive (R _{Load} < 500 Ω), 16 bit resolution, U = 30 V, accuracy: 0.1 %
Digital open-collector	Value: 0.01 ... 1000/unit, width: 1 ... 990 ms, U = 24 V, I _{max} = 4 mA
Digital relay	2 x Form A SPST (NO and NC), U = 48 V, I _{max} = 250 mA
Voltage	0 ... 10 V, R _{Load} = 1000
Frequency	2 Hz ... 10 kHz, 24 V/4 mA
HART* compatible	0/4 ... 20 mA, 24 V DC, R _{GND} = 220

TRANSDUCERS

K1P, K1L

Pipe diameter range	50 ... 500 mm for type K1P 50 ... 3,000 mm for type K1L
Dimensions of sensor heads	Type K1P: 40 (h) x 30 (w) x 30 (d) mm Type K1L: 60 (h) x 30 (w) x 35 (d) mm
Material of sensor heads	Type K1P: Plastic Type K1PL: Stainless steel
Material of cable conduits	Type K1P/L: PVC
Temperature range	Type K1P: -20 ... +50 °C (-4 ... +122 °F) Type K1L: -30 ... +80 °C (-22 ... +176 °F)
Degree of protection	IP 66 according to EN 60529 (IP 67 and IP 68 on request)
Standard cable lengths	Type K1P/L: 10 m

Images

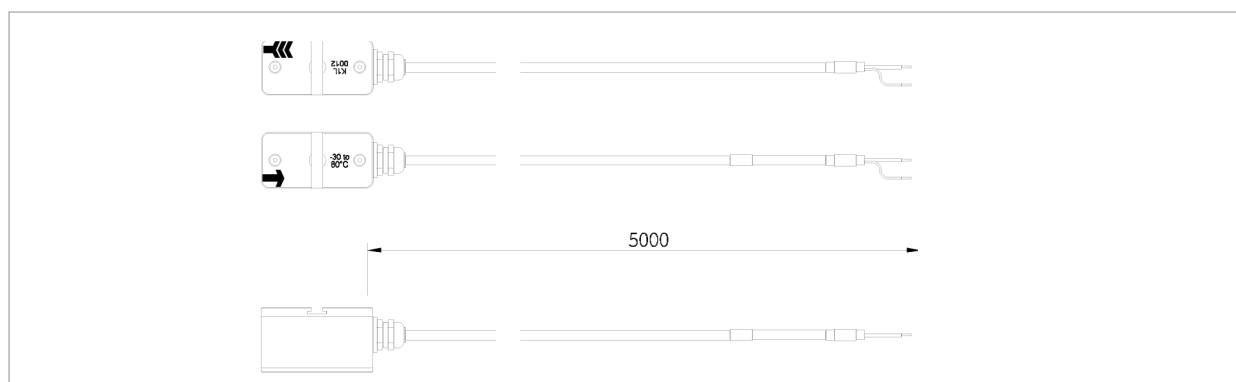

K1L transducers



K1L transducers



K1P transducers mounted using straps and clamps

K4P, K4L

Pipe diameter range	50 ... 100 mm for type K4P 10 ... 250 mm for type K4L
Dimensions of sensor heads	Type K4P: 30 (h) x 30 (w) x 30 (d) mm Type K4L: 42 (h) x 18 (w) x 22 (d) mm
Material of sensor heads	Type K4P: Plastic Type K4L: Stainless steel
Material of cable conduits	Type K4P/L: PVC
Temperature range	Type K4P: -20 ... +50 °C (-4 ... +122 °F) Type K4L: -30 ... +80 °C (-22 ... +176 °F)
Degree of protection	IP 66 according to EN 60529 (IP 67 and IP 68 on request)
Standard cable lengths	Type K4P/L: 10 m

Images

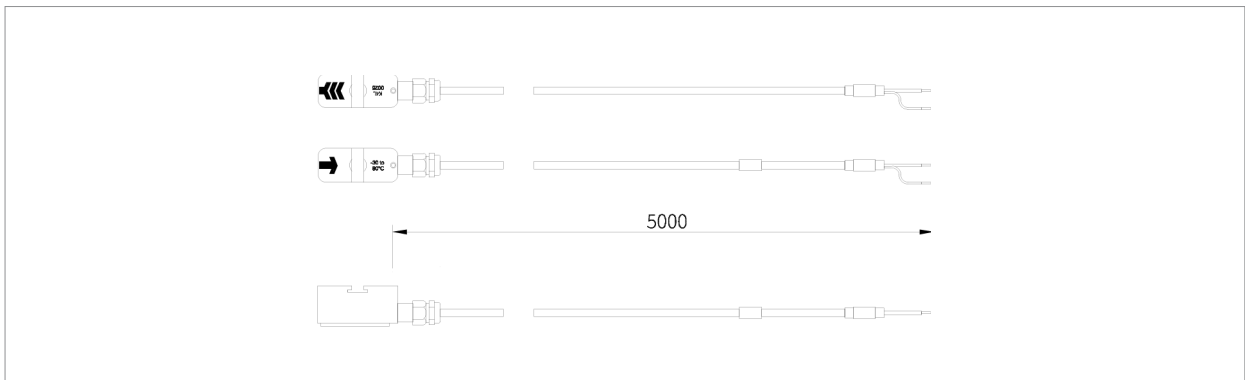

K4L transducers



K4L transducers



K4P transducers

Extension cable

Available lengths	5.0 ... 100 m
Cable type	Coaxial
Material of cable jacket	TPE
Operating temperature	-40 ... +80 °C (-40 ... +176 °F)
Minimum bend radius	67 mm

Cable connection

Connection types	Junction box
Termination into transmitter	Direct cable connection (terminal block)

TRANSDUCER MOUNTING ACCESSORIES

General

Diameter range and mounting types

Clamping set (metal strap with screw), stainless steel: DN 10 ... 40
 Metallic straps and clamps: DN 25 ... 100
 Metallic straps and clamps: DN 100 ... 3,000
 Metallic mounting rail and straps (available on request):
 DN 50 ... 250 or DN 50 ... 3,000

Mounting fixture for flexible hoses

Custom made mounting bracket, stainless steel (available on request)

Images



Metallic mounting rail with transducers



Example of mounting fixture for flexible hoses

PT100 CLAMP-ON SENSORS

General

Type	PT100 (clamp-on sensors)
Measurement range	-30 ... +250 °C (-22 ... +482 °F)
Circuits	4-wire
Accuracy T	$\pm(0.15 \text{ °C} + 2 \times 10^{-3} \times T \text{ [°C]})$, class A
Accuracy ΔT	U 0.1 K (3 K $< \Delta T < 6$ K) corresponding to EN 1434-1
Response time	50 s
Dimensions of sensor heads	20 (h) x 15 (w) x 15 (d) mm
Material of sensor heads	Aluminium
Material of cable jacket	PTFE
Cable length	3.0 m

Images

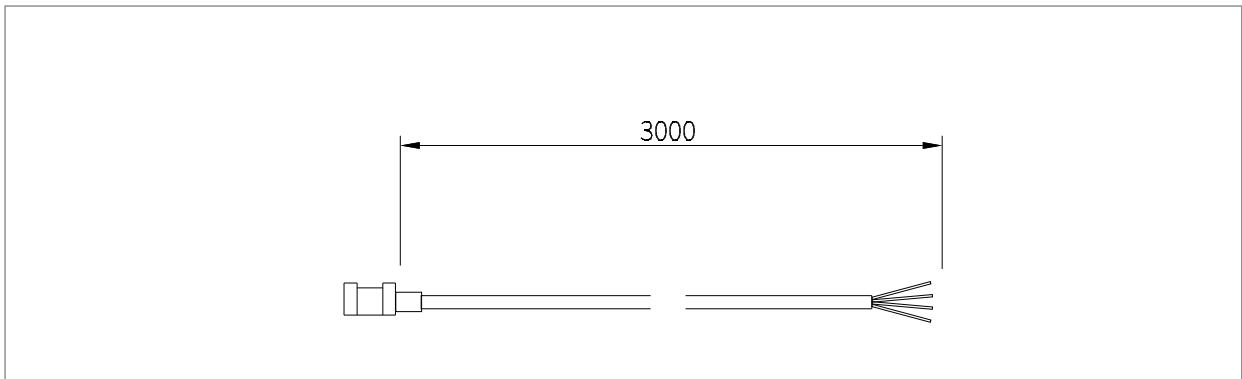

PT100 transducer



PT100 transducer fixed to pipe

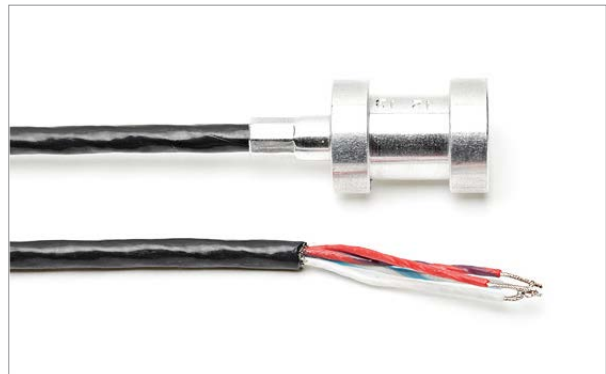

PT100 with wired cable connection

TRANSMITTER AND ACCESSORIES

KF 100	Ultrasonic flow transmitter KATflow 100, one measurement channel, serial interface RS 232, operating instructions Configuration
	2 With LCD graphic display, 128 x 64 dots, backlit and 5-key keypad
	Internal code
03	Internal code
	Power supply
	1 100 ... 240 V AC, 50/60 Hz
	2 9 ... 36 V DC
	Z Special (please specify)
	Enclosure type
	1 Die-cast aluminium, wall mounted, IP 66
	Z Special (please specify)
	Communication
	0 Without
	1 RS 485 serial interface
	2 Modbus RTU protocol ¹⁾
	Z Special (please specify)
	Process inputs/outputs (select a maximum of 4 slots)
	N Without
	Current output, 0/4 ... 20 mA, active (source) P
	Current output, 0/4 ... 20 mA, passive (sink)
	D Digital output, open-collector
	R Digital output, relay
	H HART* compatible output, 0/4 ... 20 mA ¹⁾
	V Voltage output, 0 ... 10 V
	F Frequency output, 2 Hz ... 10 kHz
	Δ x PT100 input for temperature compensation (select TC function) ²⁾ AA 2 x PT100 input for 1-channel heat quantity measurement (select HQM option no. 2) ³⁾
	B Current input, 0/4 ... 20 mA, active or passive (source/sink)
	Z Special (please specify)
	Temperature compensation (TC) ²⁾ /Heat quantity measurement (HQM) ³⁾
	0 Without
	1 With TC incl. 1 x PT100 sensor, 3 m cable ²⁾
	2 With 1-channel HQM incl. 2 x PT100 sensor, 3 m cable ³⁾
	Optional items
	Without (leave space blank)
	PS 2" pipe stand
	PM Pipe mounting bracket (diameter to be specified)
	HP Hand-held programmer

KF 100 -2 -03 -1 -1 -0 -C -0 / (example configuration)

The configuration is customised by choosing from the above-listed options and is expressed by the resulting code at the bottom of the table.

- 1) Modbus and HART* compatible outputs can not be used in conjunction with other output options. Please consult factory for more information.
- 2) For temperature compensation in cases of significant changes in medium temperature during measurement.
- 3) For contactless measurement of thermal energy consumption on a single circuit.

TRANSDUCERS AND ACCESSORIES

K4L	Transducer pair, pipe diameter range 10 ... 250 mm, process temperature -30 ... +80 °C, including acoustic coupling paste
K4P	Transducer pair, pipe diameter range 50 ... 100 mm, process temperature -20 ... +50 °C, including acoustic coupling paste
K1P	Transducer pair, pipe diameter range 50 ... 500 mm, process temperature -20 ... +50 °C, including acoustic coupling paste
K1L	Transducer pair, pipe diameter range 50 ... 3,000 mm, process temperature -30 ... +80 °C, including acoustic coupling paste
Z	Special (please consult factory)
	Internal code
	03 Internal code
	Degree of protection
	1 IP 66 (standard)
	2 IP 67 (please consult factory)
	3 IP 68 (please consult factory)
	Z Special (please specify)
	Transducer mounting accessories
	0 Without
	3 Clamping set DN 10 ... 40
	4 Metallic straps and clamps DN 25 ... 100
	5 Metallic straps and clamps DN 100 ... 3,000
	7 Metallic mounting rail and straps DN 50 ... 250 (optional for transducer type K4)
	8 Metallic mounting rail and straps DN 50 ... 3,000 (optional for transducer type K1)
	Z Special (please specify)
	Stainless steel tag
	0 Without
	1 With stainless steel tag (please specify text to be engraved)
	Transducer connection type and extension cable length
	0 Without connector or junction box
	C000 Wired transducer connection to transmitter
	J Extension via junction box (transducer type L or P)
	C005 With extension cable, 5 m length
	C010 With extension cable, 10 m length
	C___ With extension cable (specify length in m)
	Z Special (please specify)
	Optional items
	Without (leave space blank)
	CA 5-point calibration with certificate

K1L - 3 -1 -5 -0 -J -C010 / (example configuration)

The configuration is customised by choosing from the above-listed options and is expressed by the resulting code at the bottom of the table.

* HART® is a registered trademark of the HARTCommunication Foundation

U-F-M b.v. (Official Katronic distributor for the Benelux)

Argon 3
4751 XC Oud Gastel
The Netherlands

+31 (0)165 855 655
info@u-f-m.nl

www.u-f-m.com

