

FP-AS510 - Paddle Wheel Flowmeter

In-line flowrate detection for clear liquids

The Lorríc™ FP-AS510 is a compact in-line instrument for measuring the flow of a vast variety of clear liquids such as water, oil and chemicals with less particles than 1%. It has a double measuring range, which allows for the detection of any disappearance of the paddle which tends to cause "zero-flow" problems.

This paddle wheel flowmeter can be installed either vertically or horizontally and it will not affect the device's performance. It is equipped with large indicator lights and a large screen that allows for more convenient on-site supervision.

The FP-AS510 is ideal for applications where a high degree of accuracy is needed, while costs are an important factor.



Features

- Lorríc's patented AxleSense Technology™
- Pipe size : 19 ~ 51 mm
- Flow range : 0,15 ~10 m/s
- Liquid type : clear water, oil and chemicals (particles <1%)
- Set up position : horizontal and vertical
- Accuracy : ≤ 0,5% FS + 2,5% OR
- Output : 4-20mA, RS485

Recommended for

- Waste-water
- Water treatment
- Semiconductor
- Food manufacturing
- Chemical industry

AxleSense Technology™

- **Wider flowrate detection range (0,15 m/s~10m/s)** : the AxleSense Technology shifts the direction of flowrate detection, which means that even under low flow speeds, any paddle movement will be accurately sensed, as well as maintaining a low margin of error for flowrate monitoring.
- **Immediate detection of flow problems that arise from paddle disappearance** : AxleSense Technology actively detects any paddle abnormalities and offers clear information for the on-site manager to see, and will not simply display a passive “zero-flow” notice.
- **Bi-directional flow detection** : the paddle’s direction is used to detect the flow’s fundamentals, while at the same time supplies direct information about the flow direction inside the pipelines. This in conjunction with integration with the factory’s management system, makes on-site management more convenient.

LCD/LED double screen monitoring

- Double screen display: LED-5 digits LED/LCD 16x3 LCD backlight display.
- Large bright LED digits display screen for flow observation: LED’s brightness is best suited for long-distance monitoring.
- LCD screen best suited for the display of more complex text-based details.



Double LED/LCD screen

Large green, orange and red alarm indicator lights

- Large bright LED screen allows for data monitoring at any time from far away, which saves the need to constantly check the screen from up close.
- Green, orange and red indicator lights: Red – Major abnormality; Green – Normal operation; Orange – Non-urgent data display. This system’s big advantage is that no matter how far the user stands from the screen, the changing indicator light’s color can clearly indicate the status of the equipment and whether any abnormality occurs.



Three components

- **Device** : picks up the signal from the sensor, converts it into an actual flow rate or flow total value, and displays the values.
- **Paddle set** : designed to be inserted into the pipe fitting. The sensor consists of the paddlewheel with imbedded magnets and the electronic sensor.
- **Pipe fitting** : 19 ~ 51 mm, to meet the needs of different applications.



Device, paddle set and pipe fitting

The FP-AS510 paddle wheel flowmeter's three-pieces design of device, paddle set, and pipe, matches common market specifications. When wishing to replace the pipe, it is possible to replace the whole flowmeter set, allowing for more accurate flow detection, or in circumstances when the pipe cannot be replaced, it is possible to simply continue using the old one and save on the pipe replacement costs.

The flowmeter's paddle can be replaced on its own.

Dimensions

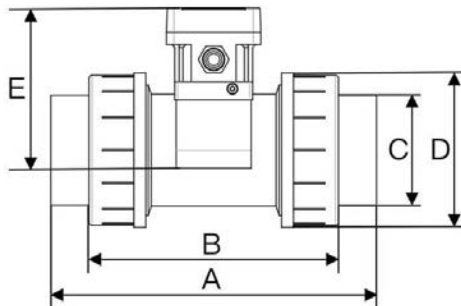

A	B	C	D	E
271,3	166,5	61	107	
F	G	H	I	J
83	77	49,4	63	63
				Unit : mm

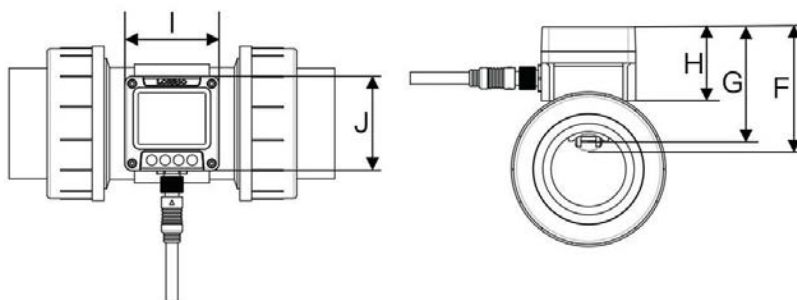

Technical specifications

Mechanism		Measurement		User Interface	
Installation method	In-line (pipe segment)	Applicable fluid maximum dynamic viscosity	300cSt	Language	English, traditional Chinese, simplified Chinese (others customizable)
Fluid in pipes temperature	Under 0~50°C	Applicable fluid	Clear, oil or chemicals with less particles (< 1 %)	Unit	Metric: litre, cubic meters, meters Time: second, minute, hour, day Imperial: foot, Cubic foot, UK gallon, US gallon
Device working environment temperature	-25~70°C	Linearity	±0,5 % FS (> 0,3 m/s)		
Tee pipe connector	PVC gluing adaptors (A S TM, JIS, DIN), PVC internal and external thread Connector (BSPT and NPT)	Reproducibility	±0,4 %	Display	Display screen display: large 5-digit LED, 16x3 3 color backlit LCD display
		OR tolerance	±2,5 % OR		
Paddle material	PVDF with embedded magnet + ceramic bearing and shaft	Measuring principle	Paddle wheel	Display digits	LED 5 digits LCD 10 digits
Tee pipe material	UPVC	Flow rate range	± 0,3 ~ 10 m/s Can extend to ±0,15 ~ 10 m/s	Operation button	4 key touch buttons
Power supply	DC 12V to 36V 100mA	Tee pipe diameter (mm)	DN20-50 (3/4" to 2")	Wired communication	Analog output 4-20 mA (external power supply required) Modbus RTU RS485 two-line OCT switch signal (ship with 2 meter cable)
Response time	< 0,5 second	Transient data	Instantaneous flow and flow rate		
Waterproof level	IP65*	Cumulative data	Positive and negative net flow accumulation, past 14 days and long time accumulative net flow	Calendar function battery	CR2032

U-F-M b.v.

Argon 3

4751 XC Oud Gastel
The Netherlands

+31 (0)165 855 655
info@u-f-m.nl

www.u-f-m.com