

ISOMAG ™

The friendly magmeter

MS 501

THE MICROFLOW SENSOR



**MICROFLOW SENSOR WITH A WIDE RANGE OF APPLICATIONS
THANKS TO THE AVAILABILITY OF DIFFERENT CONNECTION
TYPES**

Official Isoil dealer for The Netherlands:

UFM

ISOIL 
INDUSTRIA
The solutions that count

INDEX

TECHNICAL DATA	3
OVERALL FEATURES	3
STANDARD FEATURES	3
OPTIONAL FEATURES	3
OVERALL DIMENSIONS	4
GAS/NPT WITHOUT LINING	4
GAS/NPT WITH LINING	5
FLANGED WITHOUT LINING	6
FLANGED WITH PTFE LINING	7
SANITARY CLAMP CONNECTIONS	8
SANITARY DIN/SMS	9
INSTALLATION RECOMMENDATIONS	10
SENSOR GROUNDING	11
SEPARATE VERSION	12
PRESSURE LOSS CALCULATION (CONES 8° ANGLES)	13
HOW TO ORDER	14

TECHNICAL DATA

OVERALL FEATURES	
Nominal diameter	<input type="checkbox"/> DN 3 ÷ 20
Minimum conductivity	<input type="checkbox"/> 5 µS/cm
Humidity Range	<input type="checkbox"/> 0÷100% (IP 67)
Accuracy	<input type="checkbox"/> See relevant converter data sheet
CE Certification	<input type="checkbox"/> Yes

STANDARD FEATURES	
Body material	<input type="checkbox"/> AISI 304
Nominal pressure	<input type="checkbox"/> 1600 kPa
Process connections	<input type="checkbox"/> Threaded UNI 338 <input type="checkbox"/> Threaded NTP <input type="checkbox"/> Flanged UNI 2278 <input type="checkbox"/> Flanged ANSI 150 <input type="checkbox"/> Sanitary DIN 11851 <input type="checkbox"/> Clamp ISO 2852 <input type="checkbox"/> Clamp BS 4825 <input type="checkbox"/> SMS
Version – protection rating	<input type="checkbox"/> Compact IP67
Connections material	<input type="checkbox"/> AISI 316
Lining material	<input type="checkbox"/> PTFE
Gasket material	<input type="checkbox"/> FPM
Liquid temperature	<input type="checkbox"/> -20°C ÷ 100°C comp. (130°C only with ML4F-1) <input type="checkbox"/> -20°C ÷ 130°C separate
Vacuum resistance	<input type="checkbox"/> 20 Kpa absolute at 100 °C
Electrodes material	<input type="checkbox"/> AISI 316L <input type="checkbox"/> Hastelloy C <input type="checkbox"/> Platinum – rhodium <input type="checkbox"/> Titanium <input type="checkbox"/> Tantalum

OPTIONAL FEATURES (CHECK FOR MORE DETAILS 'HOW TO ORDER' ON LAST PAGE)	
Body material	<input type="checkbox"/> Stainless steel 316
Gasket material	<input type="checkbox"/> EPDM
Nominal pressure	<input type="checkbox"/> 4000kPa
Process connection	<input type="checkbox"/> Others on request
Connections material	<input type="checkbox"/> AISI 304 with lining in PTFE <input type="checkbox"/> Other on request
Electrodes material	<input type="checkbox"/> Others On request
Version – protection rating	<input type="checkbox"/> Separate (max 20m) – IP 68 <input type="checkbox"/> Separate (max 500m) with pre-amp IP 67 (IP 68 optional)

OVERALL DIMENSIONS

GAS/NPT WITHOUT LINING

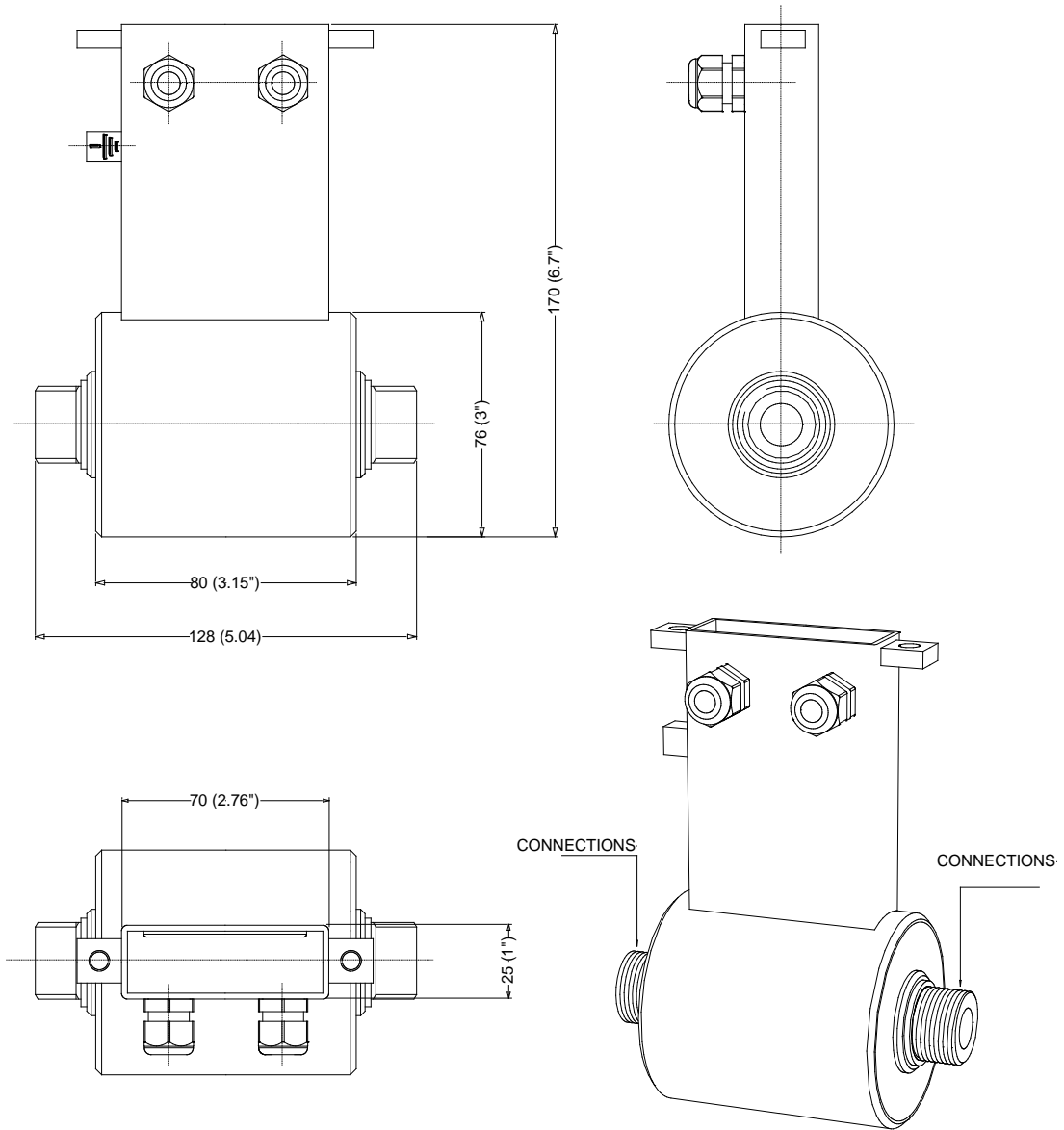

CONNECTIONS GAS/NPT (STAINLESS STEEL WITHOUT LINING)					
DIMENSIONS mm (inches)	DN				
	3 (1/8")	6 (1/4)	10 (3/8)	15 (1/2")	20 (3/4")
FITTINGS	1/4"	3/8"	1/2"	3/4"	1"

GAS/NPT WITH LINING

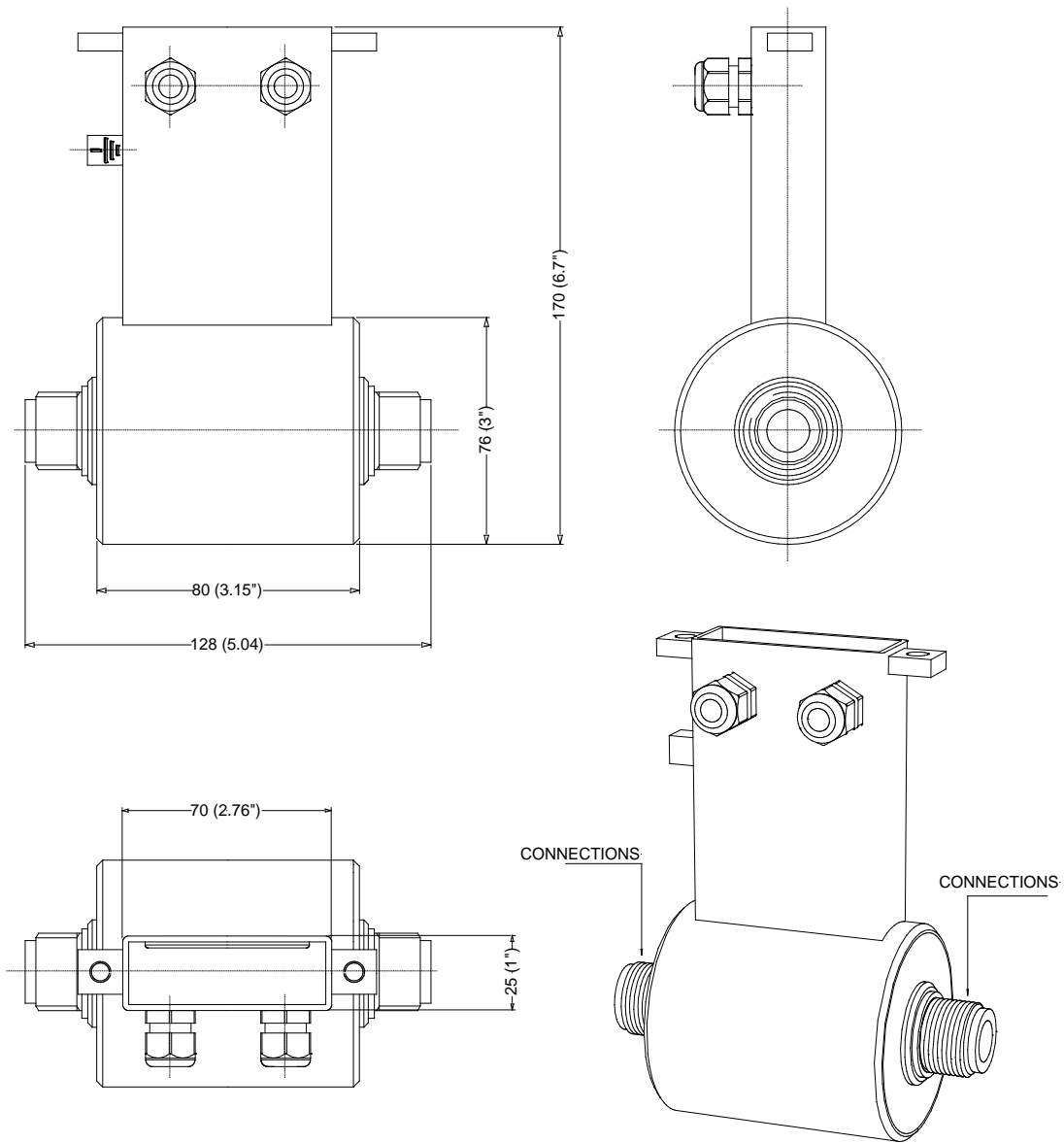

CONNECTIONS GAS/NPT (STAINLESS STEEL LINING)					
DIMENSIONS mm (inches)	DN				
	3 (1/8")	6 (1/4)	10 (3/8)	15 (1/2")	20 (3/4")
FITTINGS	1/2"	1/2"	3/4"	1"	1"1/4"

FLANGED WITHOUT LINING

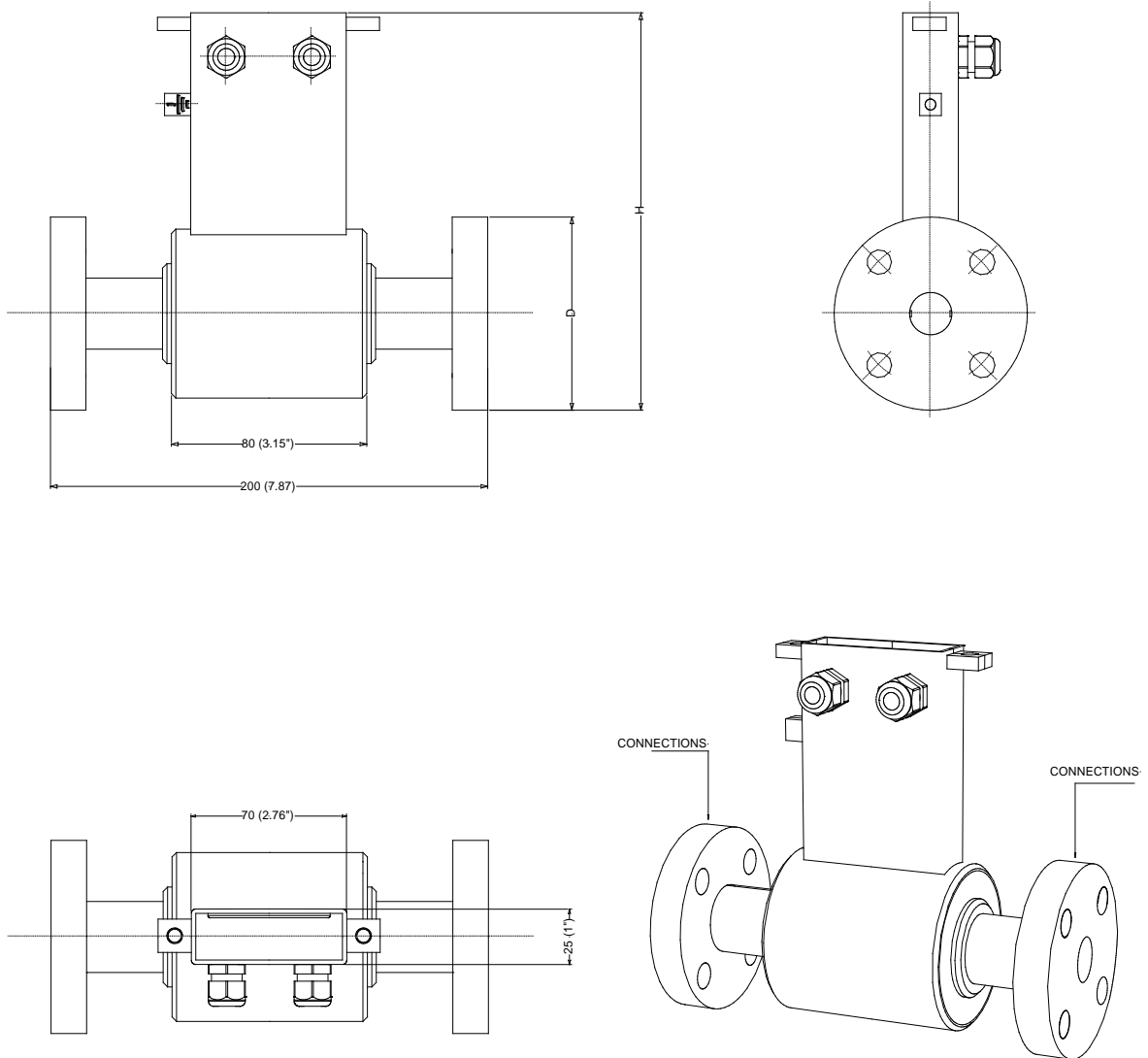

FLANGE CONNECTIONS UNI (STAINLESS STEEL WITHOUT LINING)					
DIMENSIONS mm (inches)	DN				
	3 (1/8")	6 (1/4)	10 (3/8)	15 (1/2")	20 (3/4")
D	90 (3.54)	90 (3.54)	90 (3.54)	95 (3.74)	105 (4.13)
H	183 (7.20)	183 (7.20)	183 (7.20)	186 (7.30)	191 (7.5)
FITTINGS	DN 10	DN 10	DN 10	DN 15	DN 20

FLANGE CONNECTIONS ANSI (STAINLESS STEEL WITHOUT LINING)					
DIMENSIONS mm (inches)	DN				
	3 (1/8")	6 (1/4)	10 (3/8)	15 (1/2")	20 (3/4")
D	88.9 (3.5)	88.9 (3.5)	88.9 (3.5)	88.9 (3.5)	98.4 (3.87)
H	183 (7.20)	183 (7.20)	183 (7.20)	183 (7.20)	188 (7.37)
FITTINGS	1/2"	1/2"	1/2"	1/2"	3/4"

FLANGED WITH PTFE LINING

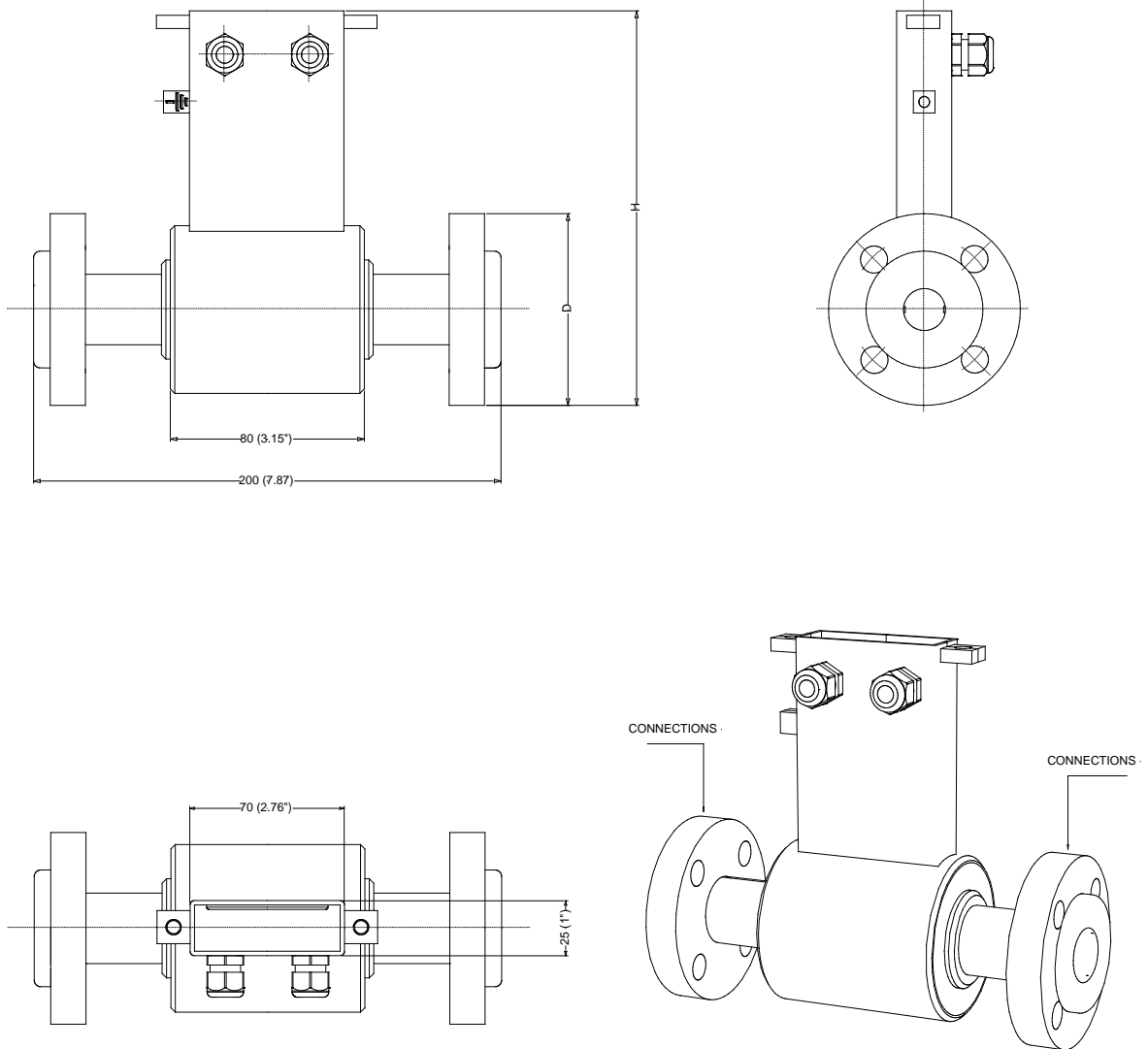

UNI FLANGE CONNECTIONS (PTFE LINING)					
DIMENSIONS mm (inches)	DN				
	3 (1/8")	6 (1/4)	10 (3/8)	15 (1/2")	20 (3/4")
D	90 (3.54)	90 (3.54)	90 (3.54)	95 (3.74)	105 (4.13)
H	183 (7.20)	183 (7.20)	183 (7.20)	186 (7.30)	191 (7.5)
FITTINGS	DN 10	DN 10	DN 10	DN 15	DN 20

ANSI FLANGE CONNECTIONS (PTFE LINING)					
DIMENSIONS mm (inches)	DN				
	3 (1/8")	6 (1/4)	10 (3/8)	15 (1/2")	20 (3/4")
D	88.9 (3.5)	88.9 (3.5)	88.9 (3.5)	88.9 (3.5)	98.4 (3.87)
H	183 (7.20)	183 (7.20)	183 (7.20)	183 (7.20)	188 (7.37)
FITTINGS	1/2"	1/2"	1/2"	1/2"	3/4"

SANITARY CLAMP CONNECTIONS

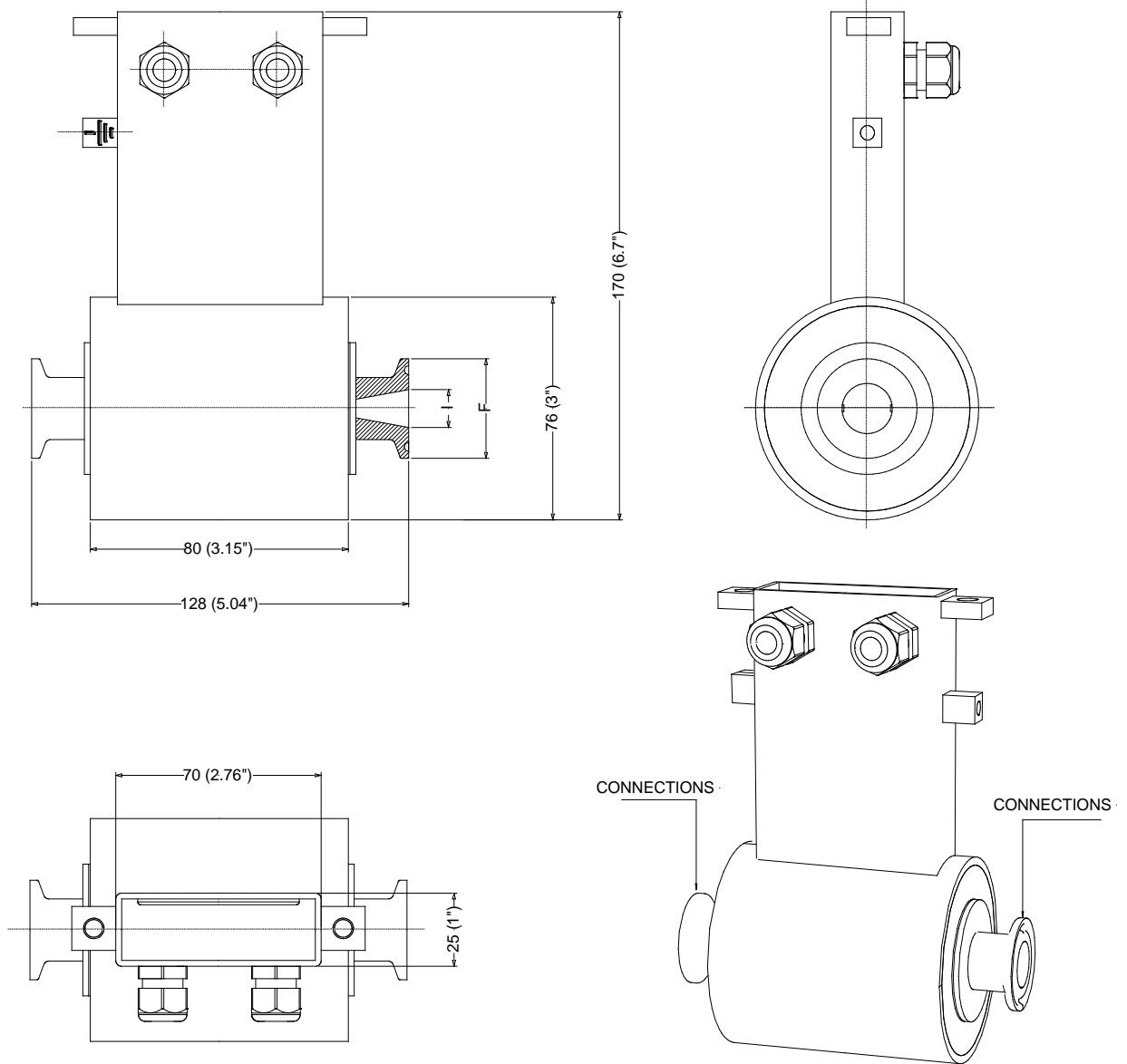

CLAMP ISO 2852					
DIMENSIONS mm (inches)	DN				
	3 (1/8")	6 (1/4)	10 (3/8)	15 (1/2")	20 (3/4")
I	12.7(0.5)	12.7(0.5)	12.7(0.5)	17.2(0.68)	21.3 (0.84)
F	34 (1.34)	34 (1.34)	34 (1.34)	34 (1.34)	34 (1.34)

CLAMP BS 4825					
DIMENSIONS mm (inches)	DN				
	3 (1/8")	6 (1/4)	10 (3/8)	15 (1/2")	20 (3/4")
I	9.5 (0.37)	9.5 (0.37)	9.5 (0.37)	15.85 (0.62)	22.2 (0.87)
F	25.4 (1)	25.4 (1)	25.4 (1)	25.4 (1)	50.5 (1.99)

SANITARY DIN/SMS

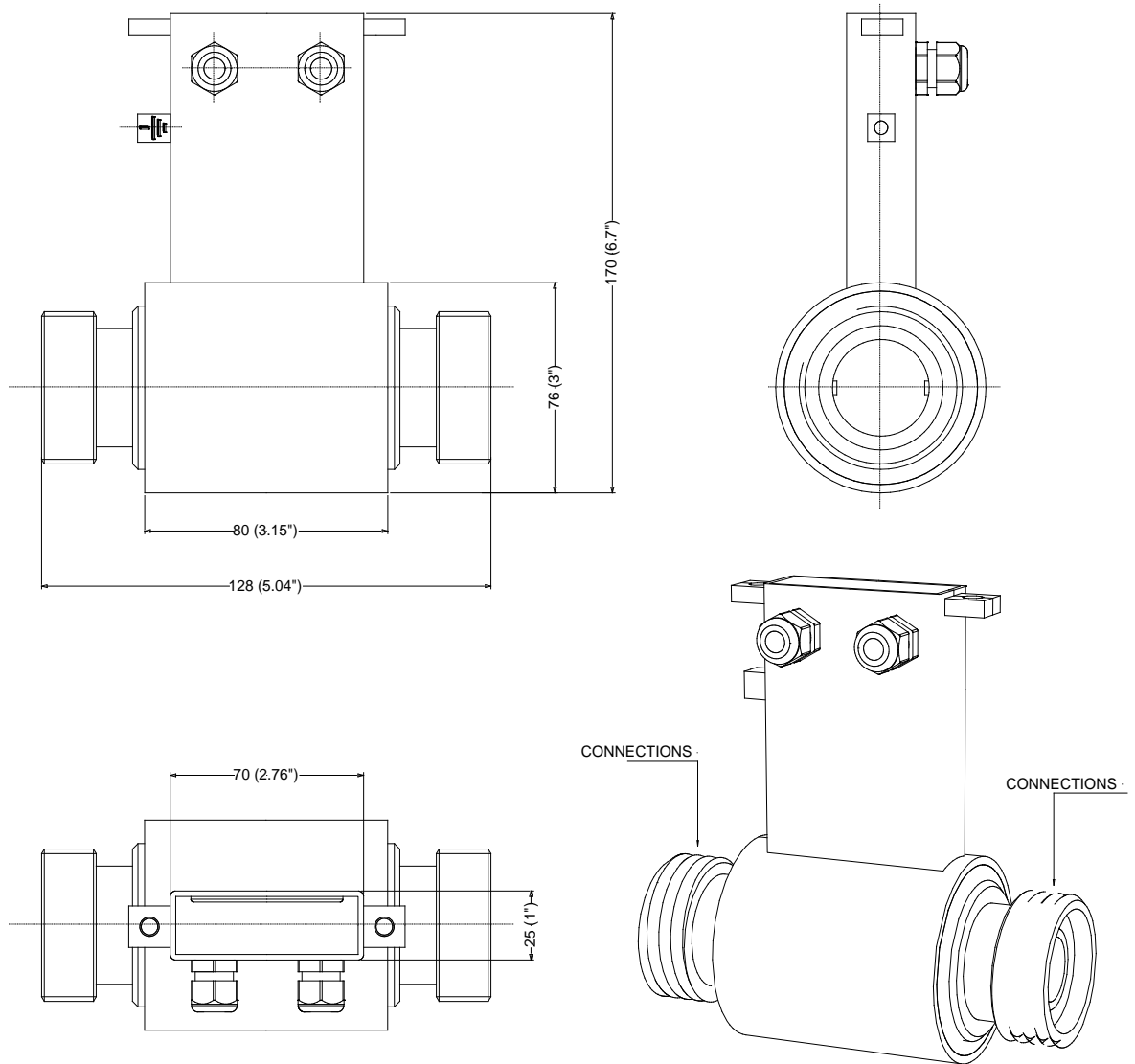

DIN 11851					
DIMENSIONS	DN				
	3 (1/8")	6 (1/4)	10 (3/8)	15 (1/2")	20 (3/4")
FITTINGS	DN 10	DN 10	DN 10	DN 15	DN 20

SMS			
DIMENSIONS			
	10 (3/8)	15 (1/2")	20 (3/4")
FITTINGS	DN 25	DN 25	DN 25

INSTALLATION RECOMMENDATIONS

In vertical installations an ascending flow is preferable. For vertical installations with descending flow direction contact the manufacturer

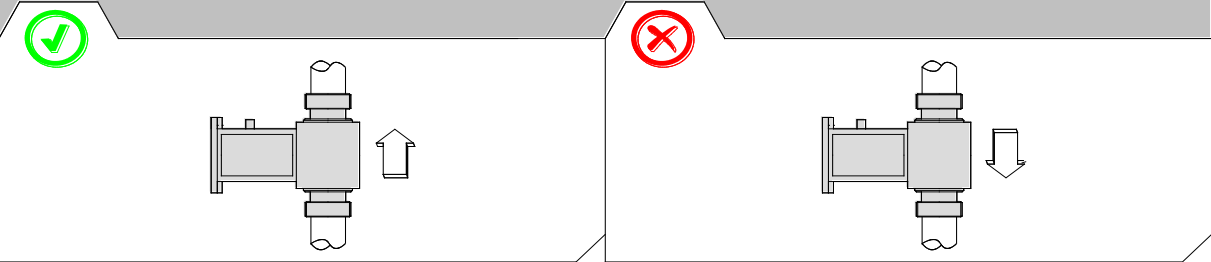

For installations in long pipe lines, please use anti vibration joints

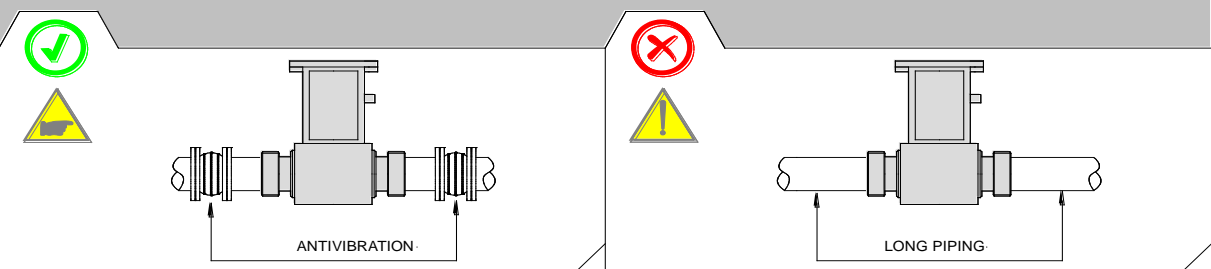

Avoid a partially empty pipe, during operation the pipe must be either completely full of liquid or completely empty

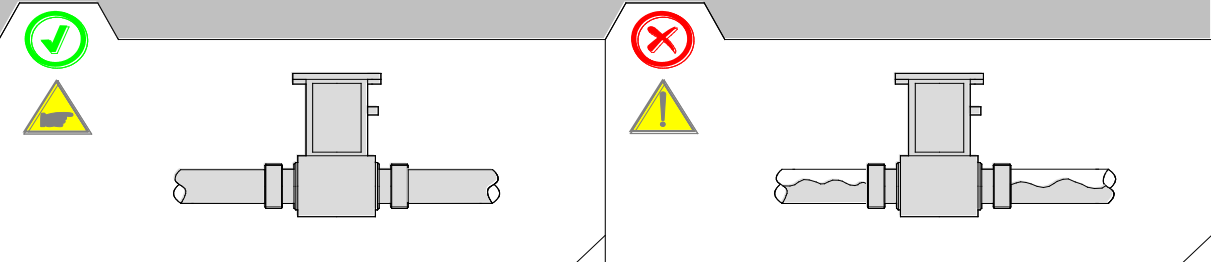

Install the sensor away from bends and hydraulic accessories and hydraulic accessories

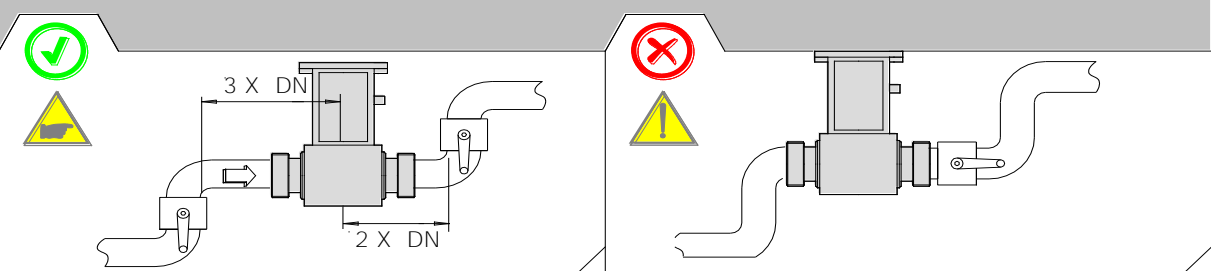

Avoid positioning flange and counter flanges by tightening the nuts.

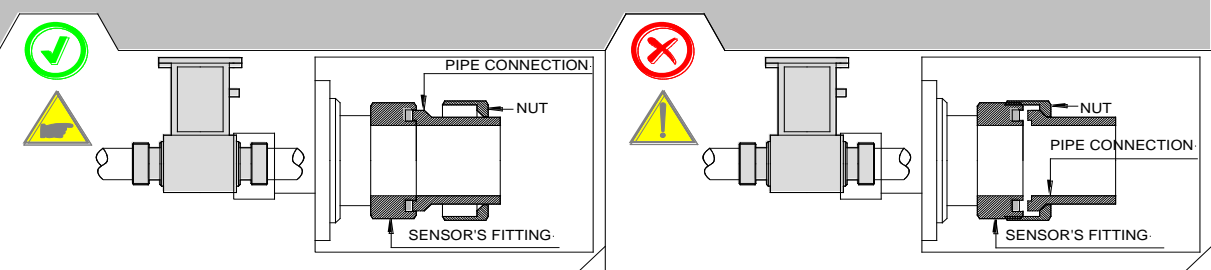

SENSOR GROUNDING

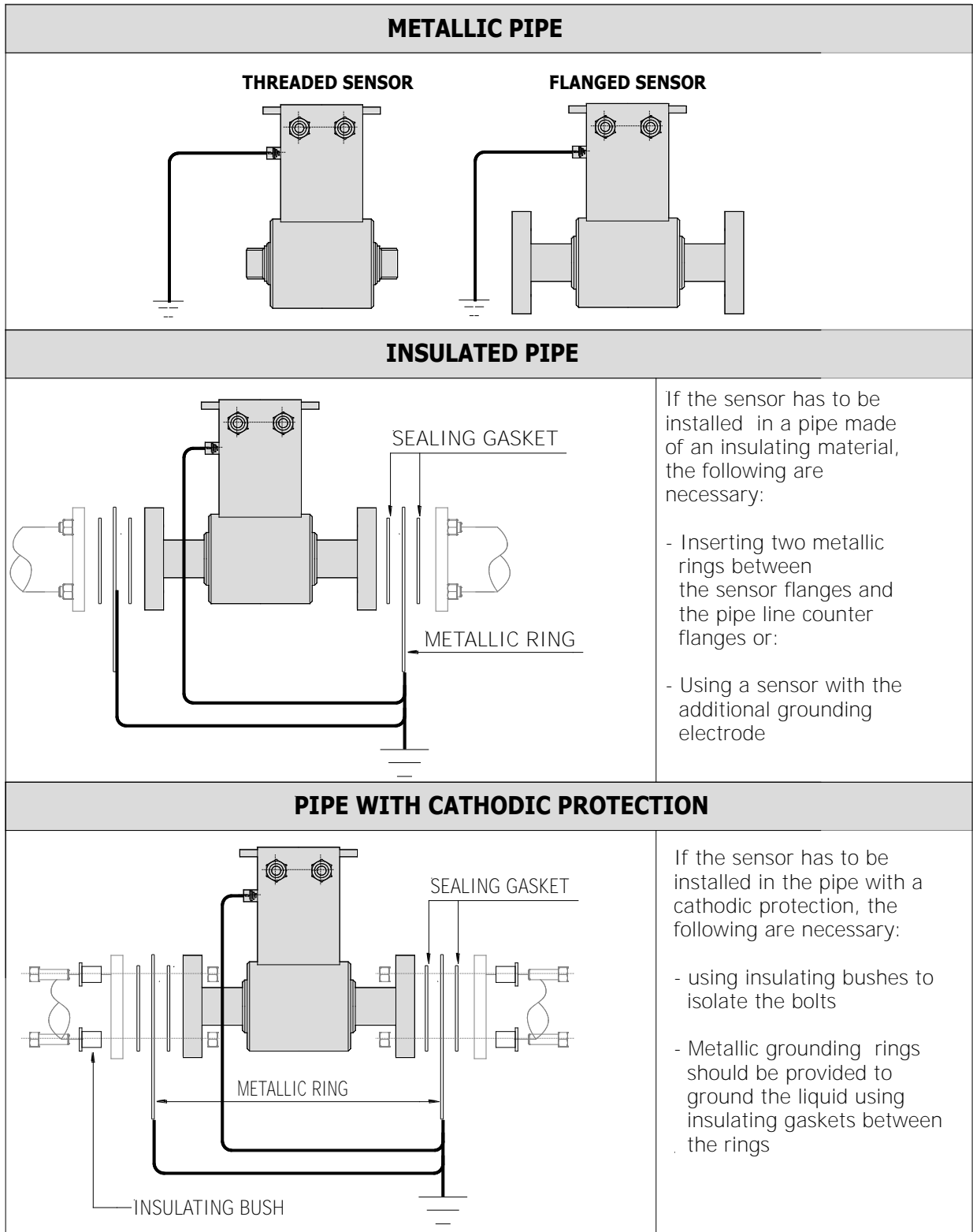

SEPARATE VERSION

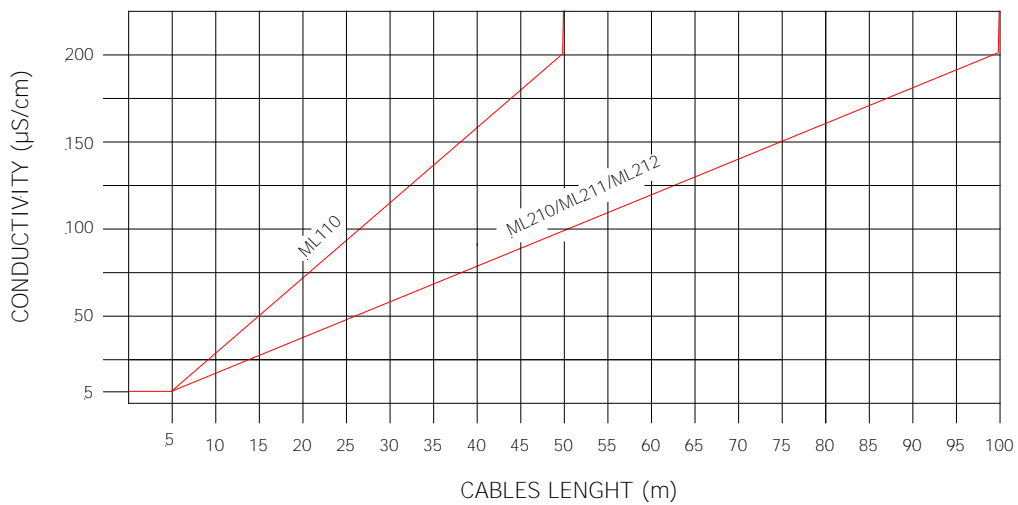
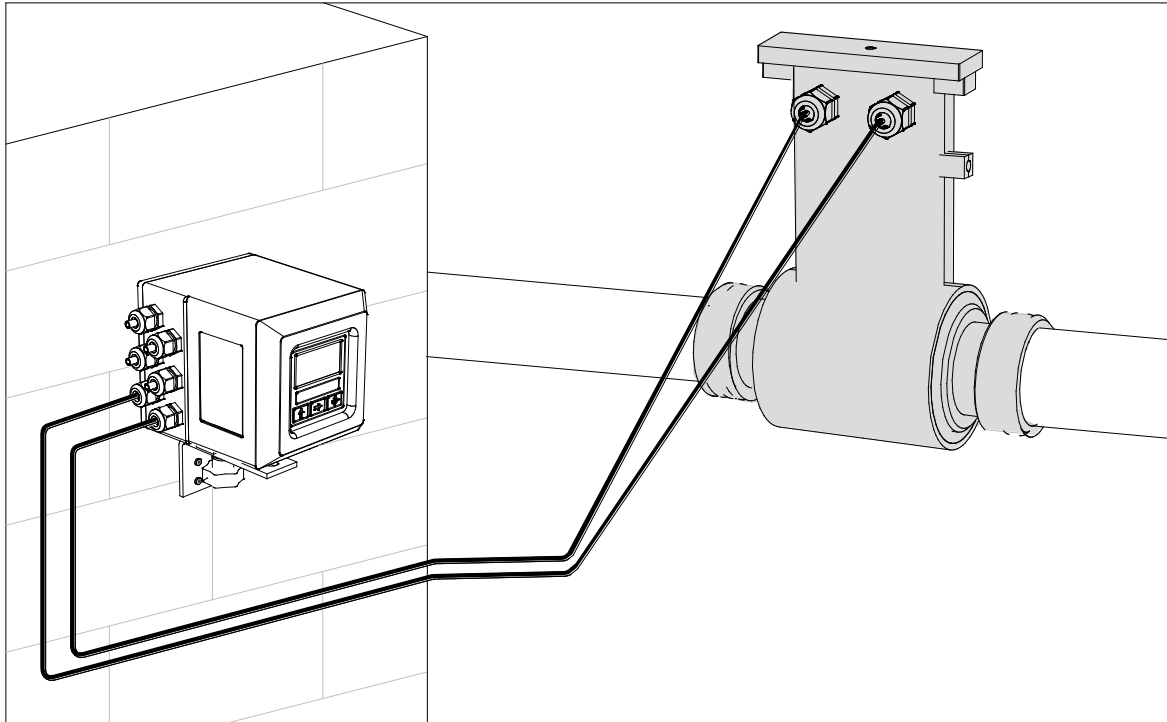
**Notes:**

- It is recommended to install the connection cables away from, or protect against sources of electromagnetic noise.
- The minimum conductivity of the liquid medium to ensure correct functionality of the empty pipe detection is 20 µS/cm

PRESSURE LOSS CALCULATION (CONES 8° ANGLES)

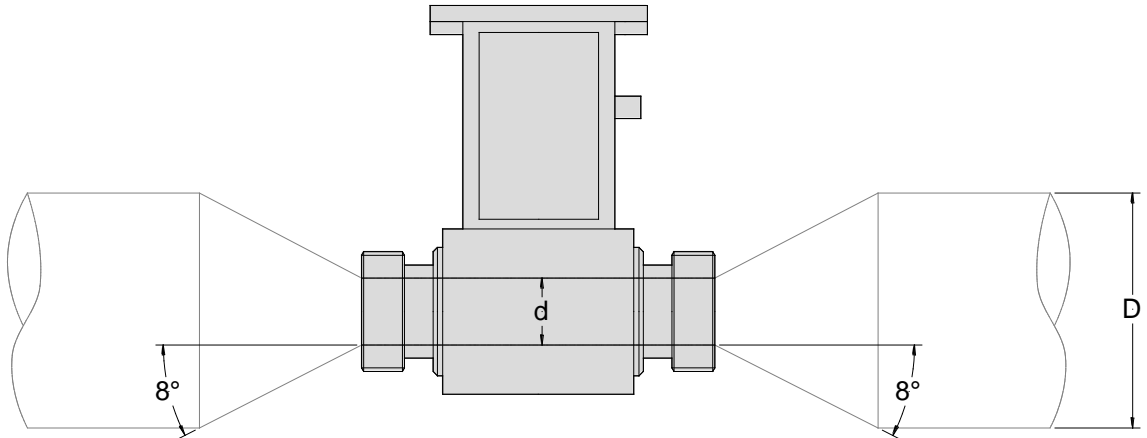

$$\Delta p = \left[0.10 + 0.20 \left(\left(\frac{d}{D} \right)^{-2} - 1 \right) \left(\frac{d}{D} \right)^4 \right] \left(\rho \frac{u^2}{2} \right)$$

Where:

Δp = Pressure loss in [Pa]

ρ = Fluid density [kg/m³] typical value $\rho = 1000$ [kg/m³]

d = sensor diameter [m]

D = pipe diameter (greater than sensor diameter) [m]

u = Mean flow velocity in sensor diameter [m/s]

Calculation examples Δp [mbar]								
$\frac{d}{D} \backslash u$	1 [m/s]	2 [m/s]	3 [m/s]	4 [m/s]	5 [m/s]	6 [m/s]	7 [m/s]	8 [m/s]
0.5	1.1	4.3	9.6	17.0	26.6	38.3	52.1	68.0
0.6	0.9	3.6	8.2	14.6	22.7	32.7	44.6	58.2
0.7	0.8	3.0	6.8	12.2	19.0	27.4	37.2	48.6
0.8	0.6	2.5	5.7	10.1	15.7	22.7	30.9	40.3
0.9	0.5	2.1	4.8	8.6	13.4	19.3	26.3	34.3

Note :

- $\rho = 1000$ [kg/m³] as goodness approximation of water density in common use.
- Inner diameter of sensor is used for d, express in meters.
- Indeed pressure loss equation is dimensionally correct in [Pa]. The equation results in table are show in [mbar].

HOW TO ORDER

MS 501	
CODE EXAMPLE	Nominal Diameter / Lining / Maximum temperature / Measuring range
T03	T03 DN3 (1/8 "), PTFE lining, measuring range 0.. 10,4 / 0...259 l/h
	T06 DN6 (1/4 "), PTFE lining, measuring range 0...41,4/0...1036 l/h
	T10 DN10 (3/8 "), PTFE lining, measuring range 0...115.2/0...2880 l/h
	T15 DN15 (1/2 "), PTFE lining, measuring range 0.. 259.2/0...6480 l/h
	T20 DN20 (3/4 "), PTFE lining, measuring range 0.. 460.8/0...11520 l/h
Gasket material (internal tightness)	
1	1 O-Ring : FKM
	2 O-Ring : Epdm
	4 O-Ring : FFKM
	9 Gasket material: to be specified
Nominal Pressure	
A	A Nominal pressure: PN16
	B Nominal pressure: PN40
	Z Nominal pressure: others on request
Process connection type	
1	1 Male threaded UNI338 (FOR THE DIMENSIONS CONSULT THE OVERALL DIMENSIONS DRAWING)
	2 Male threaded NPT(FOR THE DIMENSIONS CONSULT THE OVERALL DIMENSION DRAWING)
	3 Clamp connection, ISO2852
	4 DIN11851-852 sanitary connection
	5 SMS connection (only for DN10,15,20)
	6 UNI2278 flange connection (FOR THE DIMENSIONS CONSULT THE OVERALL DIMENSION DRAWING)
	7 ANSI 150 flange connection(FOR THE DIMENSIONS CONSULT THE OVERALL DIMENSION DRAWING)
	8 Clamp connection, BS 4825
	9 JIS flanges (10 k)
	0 Connection: other
Connection material	
A	A Connection material: AISI316
	C Connection material: AISI304, PTFE internal lining (only connection 1-2-6-7)
	9 Connection material: to be specified
Number and electrodes material	
1	1 n. 2 measure electrodes in AISI316
	4 n. 4 (2 measure + 2 for ground) electrodes in Hastelloy C
	5 n. 4 (2 measure + 2 for ground) electrodes in Titanium
	6 n. 4 (2 measure + 2 for ground) electrodes in Tantalum
	7 n. 4 (2 measure + 2 for ground) electrodes in Platinum
	0 Electrode material: to be specified
Execution / Protection rate	
A	A Compact execution, IP67 protection rate
	B Separate execution maximum length 10 m (20m, see note 1), remember to added the cables , protection rate IP68 (standing immersion with 1,5 m of head water)
	C Separate execution (in Carbon Steel), with preamplifier (maximum length 500 m.), remember to added ,protection rate IP67
	D Separate execution (in AISI304), with preamplifier (maximum length 500 m.), remember to added , protection rate IP67
	E Execution with length and position of the neck of the Sensor to define according draw. G006 (valid for A-B-C-D versions, add the relative COST)
	F Execution separate with N° 2 connectors IP 68 suitable for fast cable connections (max 20 m-ADD THE COST)
	G Execution separate with N° 1 connectors IP 68 suitable for fast cable connections (max 20 m-ADD THE COST)
	H Execution separate with N° 1 connectors IP 68 suitable for fast cable connections TO PRAMPLIFIRE IN CARBON STEEL VERSION (DEFINE THE CABLE LENGHT MAX 500 m-ADD THE COST)
	I Execution separate with N° 1 connectors IP 68 suitable for fast cable connections TO PRAMPLIFIRE IN AISI 304 VERSION (DEFINE THE CABLE LENGHT MAX 500 m-ADD THE COST)
	M Compact execution, IP67 protection rate , with the possibility to turn the converter of 90°



MS501-T03-1A1A1A (Complete code example for order)

The manufacturer reserves the right to make design improvements without notice.