

ISOMAG ™

The friendly magmeter

MS 5000

CIAO SENSOR



**EXTREMELY EASY TO INSTALL THANKS TO PATENTED WRAPPER
FIXING SYSTEM**

Official Isoil dealer for The Netherlands:

UFM

ISOIL 
INDUSTRIA
The solutions that count

INDEX

TECHNICAL DATA	3
OVERALL FEATURES	3
STANDARD FEATURES	3
OPTIONAL FEATURES	3
OVERALL DIMENSIONS.....	4
INSTALLATION.....	5
INSTALLATION RECOMMENDATION	6
SEPARATE VERSION	7
PRESSURE LOSS CALCULATION	8
(CONES 8° ANGLES).....	8
HOW TO ORDER	9

TECHNICAL DATA

<i>OVERALL FEATURES</i>	
Nominal diameter	<input type="checkbox"/> DN 25 – 50 – 80
Minimum conductivity	<input type="checkbox"/> 5 μ S/cm
Humidity Range	<input type="checkbox"/> 0 ÷ 100% (IP 67)
Accuracy	<input type="checkbox"/> See relevant converter data sheet
CE Certification	<input type="checkbox"/> Yes

<i>STANDARD FEATURES</i>	
Body material	<input type="checkbox"/> Polyurethane rubber
Nominal pressure	<input type="checkbox"/> 600 kPa
Process connection	<input type="checkbox"/> Wrapper fixing
Version – protection rating	<input type="checkbox"/> Compact IP67
Lining material	<input type="checkbox"/> Polyurethane rubber
Gasket material	<input type="checkbox"/> FPM
Liquid temperature	<input type="checkbox"/> 0°C ÷ 50°C
Vacuum resistance	<input type="checkbox"/> 20 Kpa a 50 °C
Electrodes material	<input type="checkbox"/> SS AISI 316L <input type="checkbox"/> Hastelloy C <input type="checkbox"/> Titanium

<i>OPTIONAL FEATURES</i> (CHECK FOR MORE DETAILS 'HOW TO ORDER' ON LAST PAGE)	
Gasket material	<input type="checkbox"/> EPDM
Version – protection rating	<input type="checkbox"/> Separate (max 20m) – IP 68

OVERALL DIMENSIONS

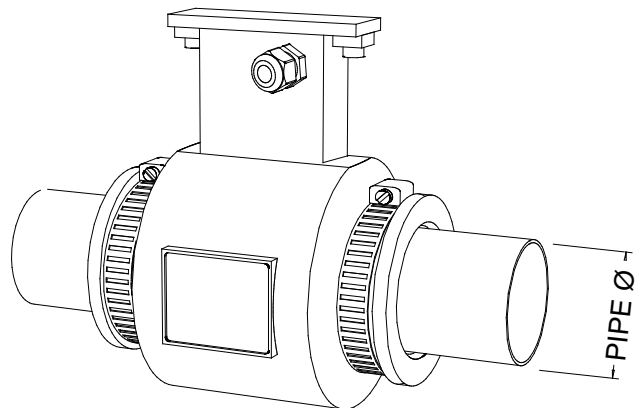
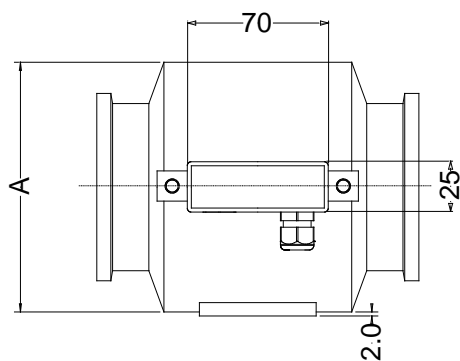
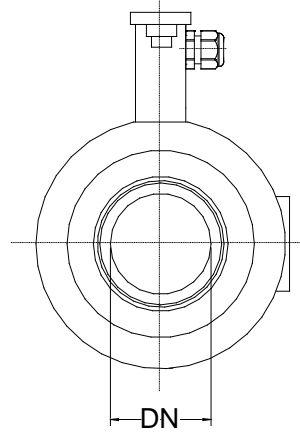
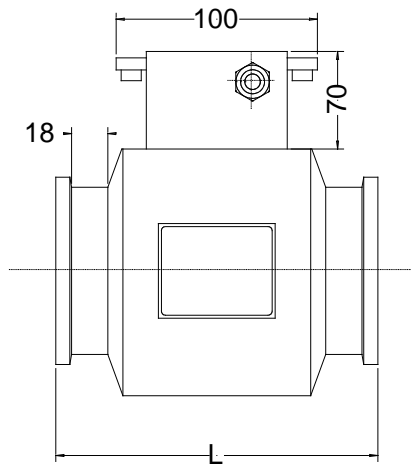

DIMENSIONS mm	25 (1")	50 (2")	80 (3")
	A	80	124
L	135	160	190
PIPE Ø (ISO)	33.7	60.3	88.9

INSTALLATION

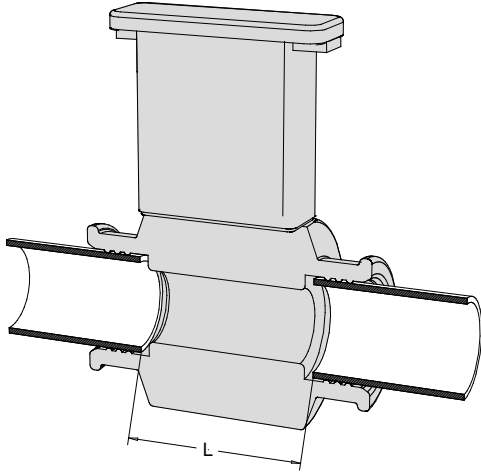

DN	L (mm)	L (inches)
25	92	3.62
50	108	4.25
80	138	5.43

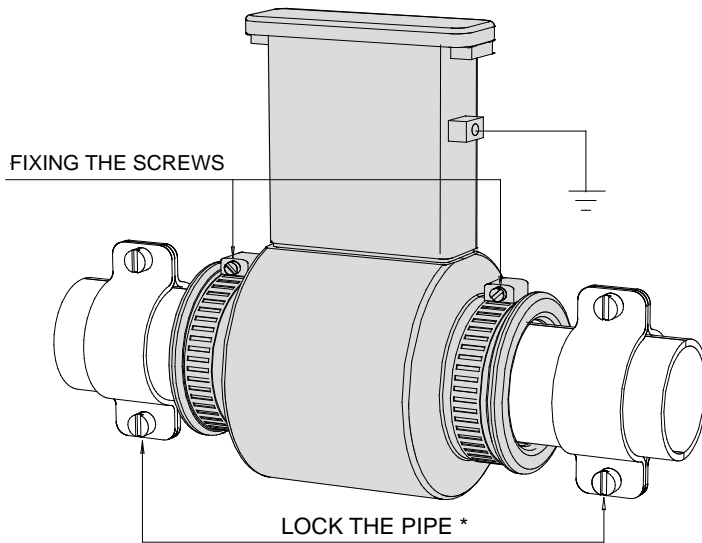

* Lock the pipe to a fixed support

- Verify the flow direction
- Assemble the sensor to the pipe
- Tighten the wrapper to avoid possible leakages
- Connect the instrument to ground by the screw attachment on sensor

INSTALLATION RECOMMENDATION

In vertical installations an ascending flow is preferable. For vertical installations with descending flow direction contact the manufacturer.

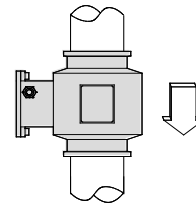
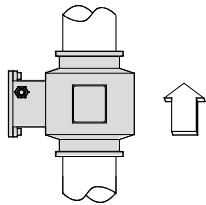

For installations in long pipe lines, please use anti vibration joints

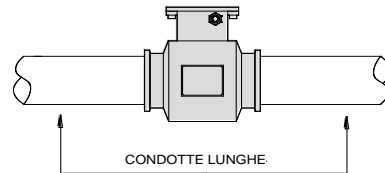
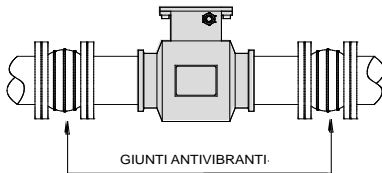

Avoid the functioning with partially empty pipe, during the functioning the pipe must be either completely full of liquid or completely empty

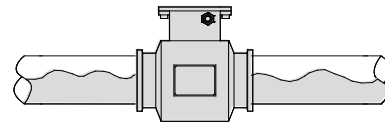
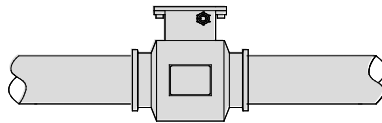

Install the sensor away from bends and hydraulic accessories

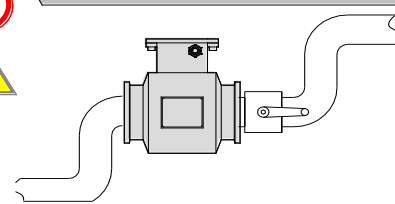
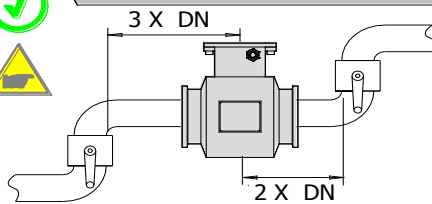

SEPARATE VERSION

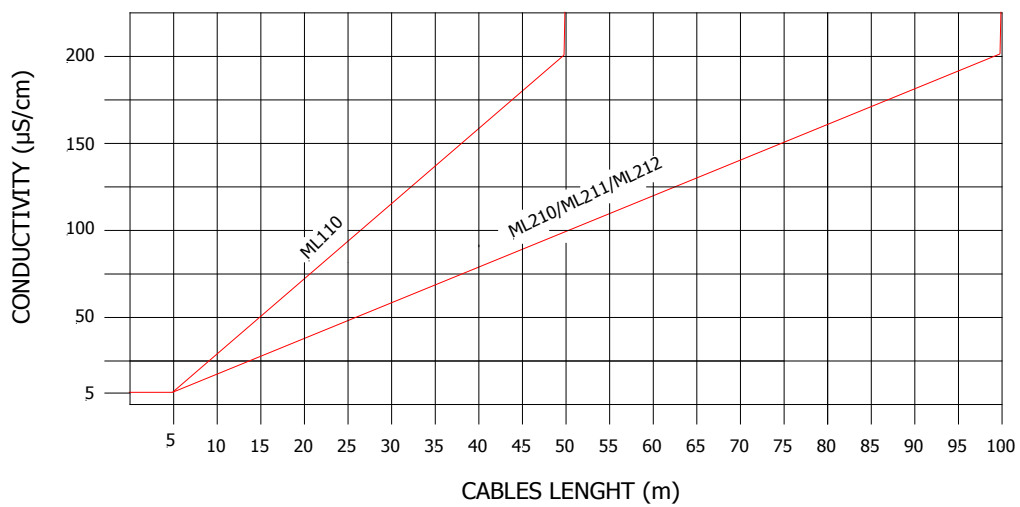
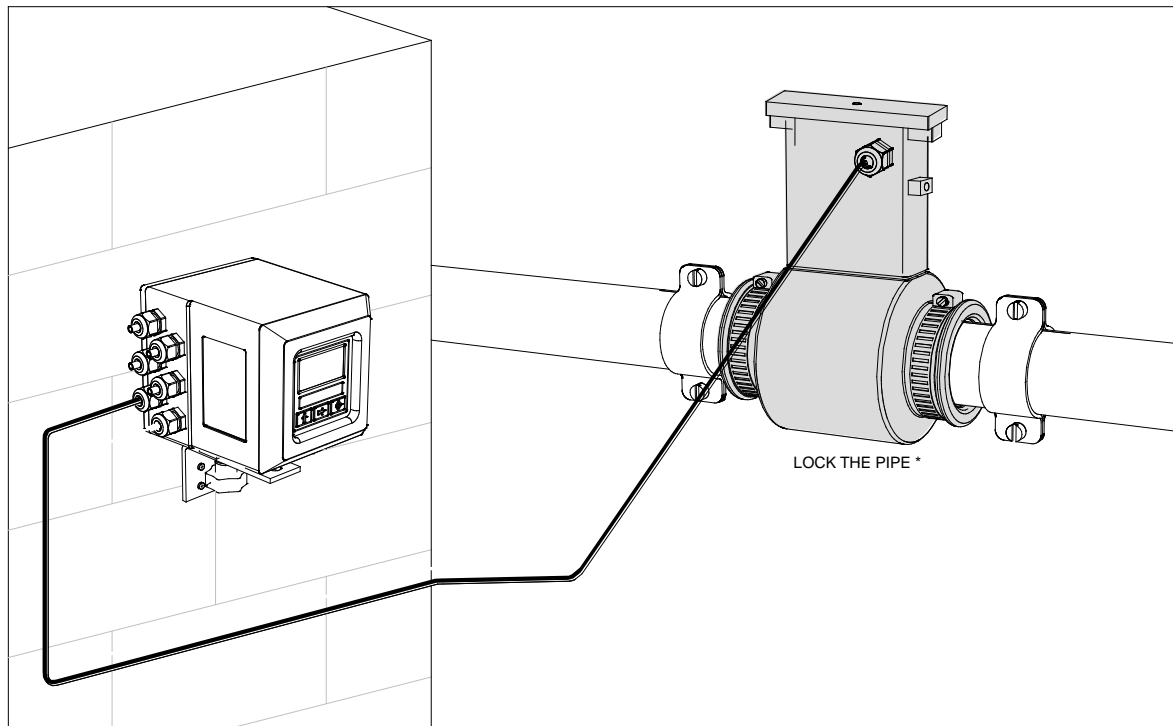
**Notes:**

- It is recommended to install the connection cables away from, or protect against sources of electromagnetic noise.
- The minimum conductivity of the liquid medium to ensure correct functionality of the empty pipe detection is 20 µS/cm

PRESSURE LOSS CALCULATION (CONES 8° ANGLES)

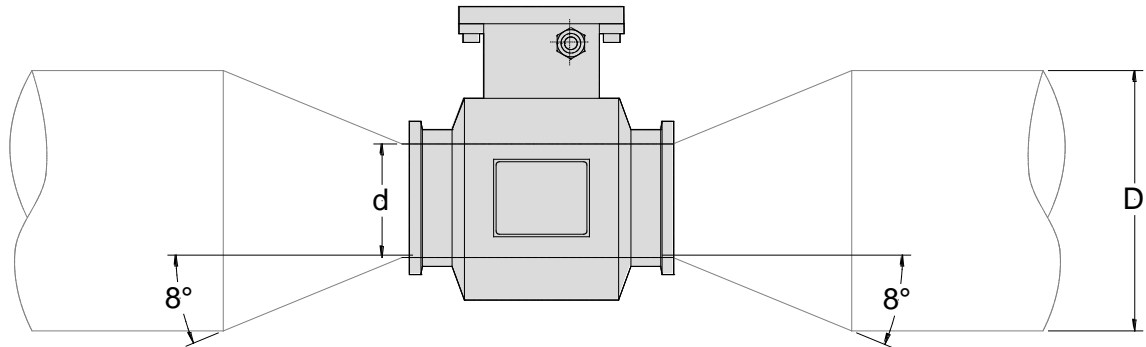

$$\Delta p = \left[0.10 + 0.20 \left(\left(\frac{d}{D} \right)^{-2} - 1 \right) \left(\frac{d}{D} \right)^4 \right] \left(\rho \frac{u^2}{2} \right)$$

Where:

Δp = Pressure loss in [Pa]

ρ = Fluid density [kg/m^3] typical value $\rho = 1000[\text{kg}/\text{m}^3]$

d = sensor diameter [m]

D = pipe diameter (greater than sensor diameter) [m]

u = Mean flow velocity in sensor diameter [m/s]

Calculation examples Δp [mbar]								
$\begin{matrix} u \\ d/D \end{matrix}$	1 [m/s]	2 [m/s]	3 [m/s]	4 [m/s]	5 [m/s]	6 [m/s]	7 [m/s]	8 [m/s]
0.5	1.1	4.3	9.6	17.0	26.6	38.3	52.1	68.0
0.6	0.9	3.6	8.2	14.6	22.7	32.7	44.6	58.2
0.7	0.8	3.0	6.8	12.2	19.0	27.4	37.2	48.6
0.8	0.6	2.5	5.7	10.1	15.7	22.7	30.9	40.3
0.9	0.5	2.1	4.8	8.6	13.4	19.3	26.3	34.3

Note :

- $\rho = 1000[\text{kg}/\text{m}^3]$ as goodness approximation of water density in common use.
- Inner diameter of sensor is used for d , express in meters.
- Indeed pressure loss equation is dimensionally correct in [Pa]. The equation results in table are show in [mbar].

HOW TO ORDER

Example code	MS 5000	
	Nominal Diameter / Lining / Liquid temperature / Measuring range	
C25	C25	DN25 (1"), measuring range 0...0,73/0...18 m3/h
	C50	DN50 (2"), measuring range 0...2,92/0...72 m3/h
	C80	DN80 (3"), measuring range 0...7,50/0...184 m3/h
Gasket material (internal tightness)		
A	A	Without gasket
Number and electrodes material		
2	2	n. 3 measure electrodes in AISI316
	4	n. 3 (2 measure + 1 for ground) electrodes in Hastelloy C
	5	n. 3 (2 measure + 1 for ground) electrodes in Titanium
Version / Classe di protezione sensore		
A	A	Compact execution, IP67 protection rate, liquid maximum temperature 50 °C
	B	Separate execution , maximum length 20m, remember to added the cables cost , protection rate IP68 (standing immersion with 1,5 m of head water)
	M	Compact execution, IP67 protection rate , with the possibility to turn the converter of 90°



MS5000-C25-A2A (Complete code example for order)

The manufacturer reserves the right to make design improvements without notice.