

ISOMAG

The friendly magmeter

MS 1000

WAFER TYPE SENSOR



"WAFER" TYPE SENSOR SUITABLE FOR SEVERAL FLANGE TYPES

Official Isoil dealer for The Netherlands:

UFM

ISOIL 
INDUSTRIA
The solutions that count

INDEX

TECHNICAL DATA	3
OVERALL FEATURES	3
STANDARD FEATURES	3
OPTIONAL FEATURES	3
OVERALL DIMENSIONS	4
VERSIONS	5
TORQUES (Nm)	6
INSTALLATION RECOMMENDATIONS	7
RECOMMENDED INSTALLATION METHOD	8
SENSOR GROUNDING	9
SEPARATE VERSION	10
PRESSURE LOSS CALCULATION	11
(CONES 8° ANGLES)	11
HOW TO ORDER	12

TECHNICAL DATA

OVERALL FEATURES	
Nominal diameter	<input type="checkbox"/> DN 25 ÷ 400
Minimum conductivity	<input type="checkbox"/> 5 µS/cm
Humidity Range	<input type="checkbox"/> 0÷100% (IP 67)
Accuracy	<input type="checkbox"/> See relevant converter data sheet
CE Certification	<input type="checkbox"/> Yes

STANDARD FEATURES	
Body material	<input type="checkbox"/> Carbon steel painted
Nominal pressure	<input type="checkbox"/> 1600 kPa : all with PP and Ebonite lining <input type="checkbox"/> 4000 kPa : PTFE lining up to DN 150
Process connection	<input type="checkbox"/> Wafer Type
Version – protection rating	<input type="checkbox"/> Compact IP67 (IP68 on request)
Lining material	<input type="checkbox"/> Polypropylene (max PN 16) <input type="checkbox"/> Ebonite (DN 200 – 400) <input type="checkbox"/> PTFE (DN 25 – 200)
Gasket material (ONLY for lining in Polypropylene)	<input type="checkbox"/> FPM
Liquid temperature	<input type="checkbox"/> 0°C ÷ 60°C with PP lining <input type="checkbox"/> -5°C ÷ 80°C with ebonite lining <input type="checkbox"/> -20°C ÷ 100°C with PTFE lining in compact version
Vacuum resistance	<input type="checkbox"/> 20 Kpa (absolute) at 100 °C (60/80°C for PP/Ebonite)
Electrodes material	<input type="checkbox"/> Stainless steel AISI 316 <input type="checkbox"/> Hastelloy C <input type="checkbox"/> Platinum-rhodium <input type="checkbox"/> Titanium <input type="checkbox"/> Tantalum

OPTIONAL FEATURES (CHECK FOR MORE DETAILS 'HOW TO ORDER' ON LAST PAGE)	
Body material	<input type="checkbox"/> Stainless steel AISI 304 or 316
Gasket material (ONLY for lining in Polypropylene)	<input type="checkbox"/> EPDM
Liquid temperature	<input type="checkbox"/> -20°C ÷ 110°C with PTFE lining in separate version* * Contact the factory for higher temperature
Lining material	<input type="checkbox"/> On request
Electrodes material	<input type="checkbox"/> On request
Grounding electrode	<input type="checkbox"/> On request
Version – protection rating	<input type="checkbox"/> Separate version (max 20m) – IP 68 <input type="checkbox"/> Separate version (max 500 m), with preamplifier – IP 67 <input type="checkbox"/> Separate version (max 500 m), with preamplifier – IP 68

OVERALL DIMENSIONS

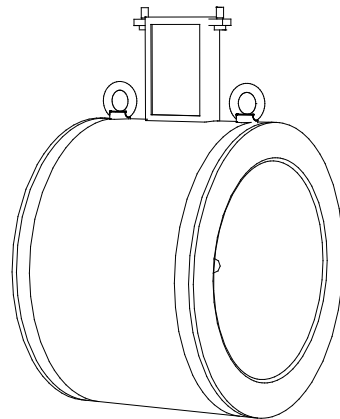
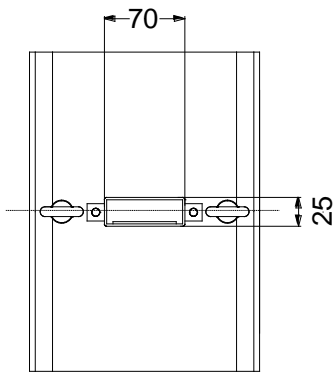
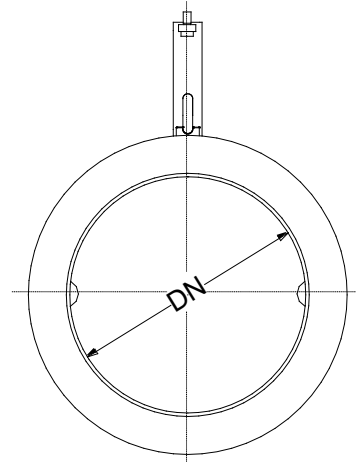
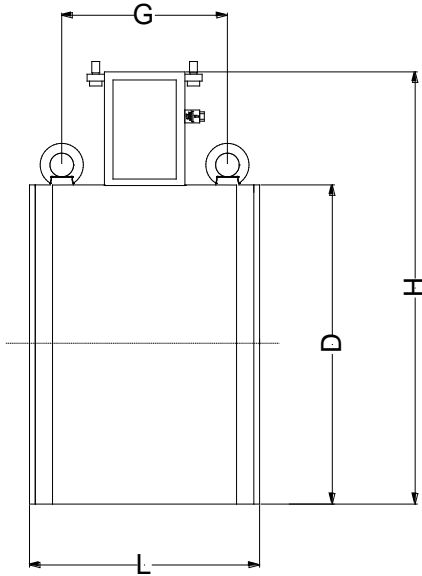

DIMENSIONS mm (inches)	ND													
	25 (1")	32 (1" 1/4)	40 (1" 1/2)	50 (2")	65 (2" 1/2)	80 (3")	100 (4")	125 (5")	150 (6")	200 (8")	250 (10")	300 (12")	350 (14")	400 (16")
L	+0 -3 (-0.12)	+0 -3 (-0.12)	+0 -3 (-0.12)	+0 -3 (-0.12)	+0 -3 (-0.12)	+0 -3 (-0.12)	+0 -3 (-0.12)	+0 -3 (-0.12)	+0 -3 (-0.12)	+0 -3 (-0.12)	+0 -5 (-0.20)	+0 -5 (-0.20)	+0 -5 (-0.20)	+0 -5 (-0.20)
H	100 (3.94)	100 (3.94)	100 (3.94)	100 (3.94)	150 (5.90)	150 (5.90)	150 (5.90)	180 (7.09)	180 (7.09)	180 (7.09)	200 (7.87)	250 (9.84)	300 (11.81)	350 (13.78)
D	147 (5.79)	153 (6.02)	161 (6.34)	177 (6.97)	199 (7.83)	209 (8.23)	235 (9.25)	263 (10.35)	291 (11.46)	362 (14.25)	417 (16.42)	467 (18.39)	527 (20.75)	579 (22.80)
G	62 (2.44)	67 (2.63)	78 (3.07)	92 (3.62)	108 (4.25)	118 (4.65)	144 (5.67)	172 (6.77)	200 (7.87)	271 (10.67)	326 (12.83)	376 (14.80)	436 (17.17)	488 (19.21)
Weight kg (lbs)	1.2 (2.64)	1.6 (3.52)	1.8 (3.96)	2 (4.4)	3.6 (7.92)	3.8 (8.36)	5 (11)	7.8 (17.16)	8.2 (18)	18.2 (40)	24 (53)	27 (59)	32 (70)	39 (86)
Usable flanges	PN10, PN16, PN25, PN40, ANSI150, ANSI,300										PN10, PN16, ANSI150			

VERSIONS

COMPACT VERSION

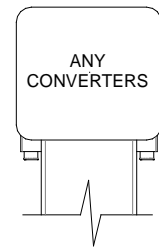
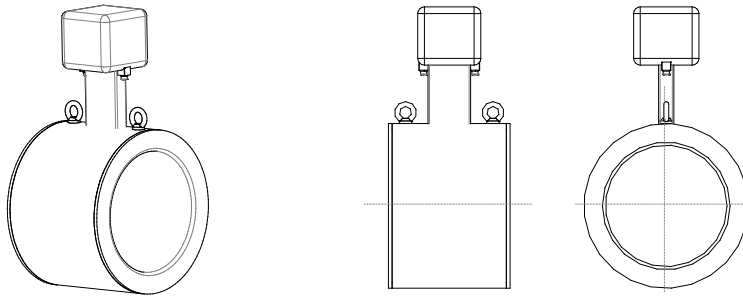

The overall dimension of coverter are showed in the suitable manual

SEPARATE VERSION FOR PAINTED SENSORS

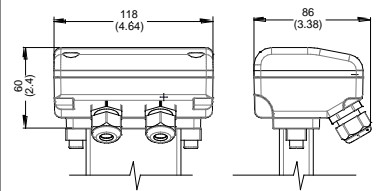
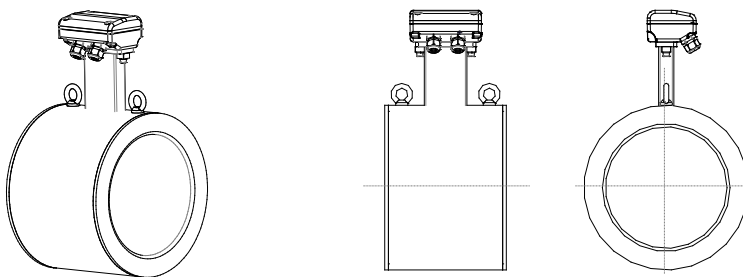

Sensor with junctions box

SEPARATE VERSION FOR STAINLESS STEEL SENSORS

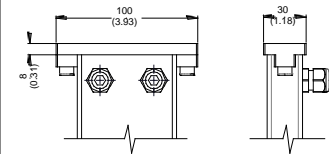
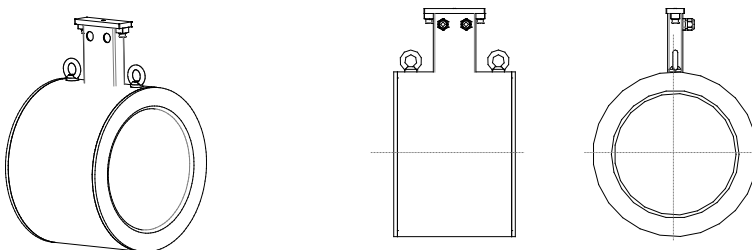

Sensor with cover

SEPARATE VERSION FOR SENSOR WITH PREAMPLIFIER

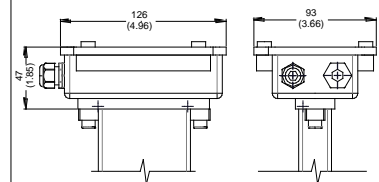
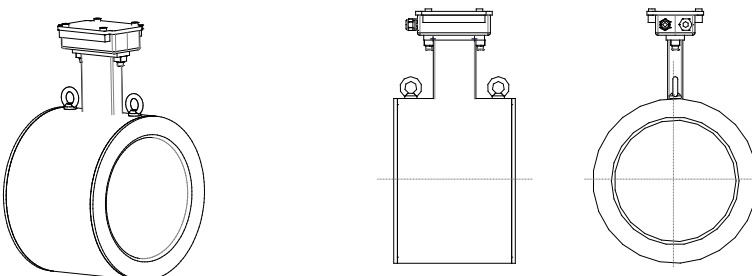

Sensor with preamplifier

TORQUES (Nm)

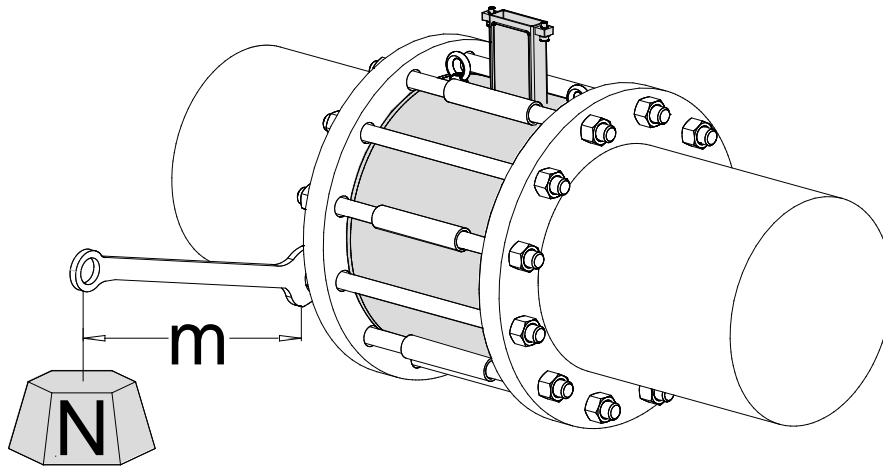

		OPERATING PRESSURE								
Kpa	1000	1600			2500		4000		6400	
psi	140	260			350		600		1000	
DN	PTFE	EBON.	PTFE	EBON.	PP	PTFE	EBON.	PTFE	EBON.	EBON.
25			25		19	25		25		39
32			43		28	43		43		53
40			53		36	53		53		72
50			68		52	68		68		81
65			90		75	45		45		58
80			53		41	53		53		62
100			59		56	83		83		87
125			77		71	112		112		148
150			108		106	135		135		217
200	148	123		82			112		149	233
250	123	103		117			170		223	321
300	142	119		146			168		232	317
350	172	143		171			270		352	481
400	217	181		235			355		516	623

- Tighten uniformly in diagonally opposite sequence
- The torque listed in the tab is applicable to the following flanges types:
EN1092-1, DIN 2501, BS 4504, ANSI B16.5 , JIS
- The use of gaskets DIN 2690 is recommended

INSTALLATION RECOMMENDATIONS

In vertical installations an ascending flow is preferable. For vertical installations with descending flow direction contact the manufacturer

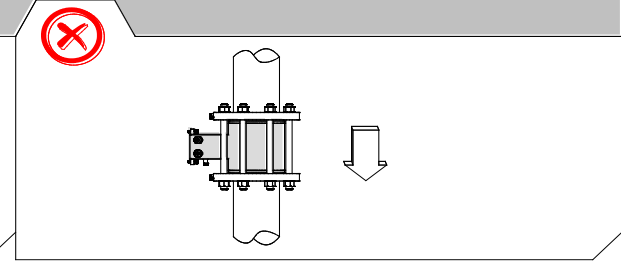
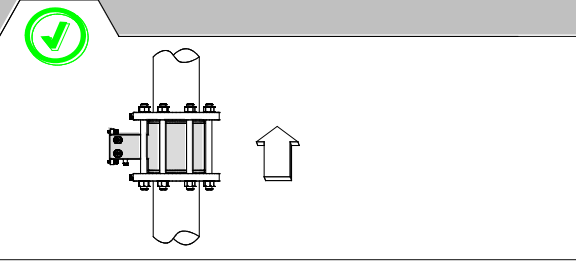

For installations in long pipe lines, please use anti vibration joints

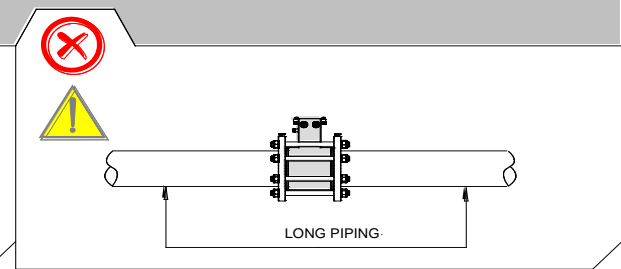
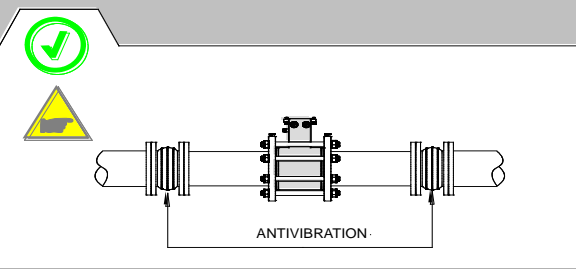

Avoid a partially empty pipe, during operation the pipe must be either completely full of liquid or completely empty

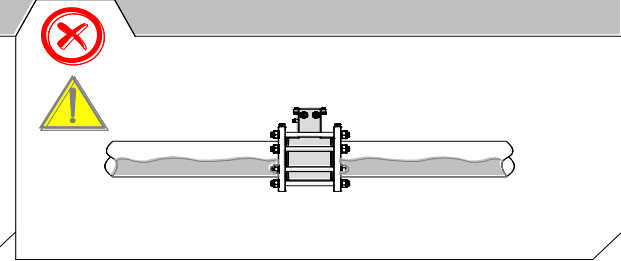
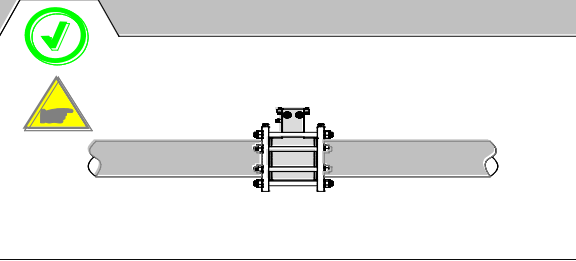

Install the sensor away from bends and hydraulic accessories

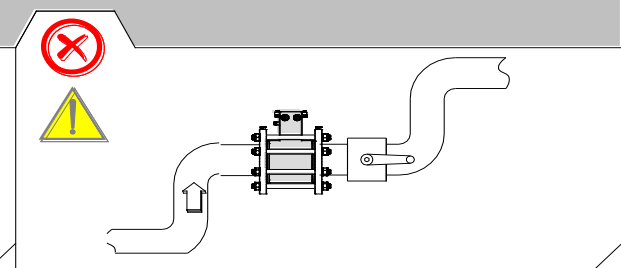
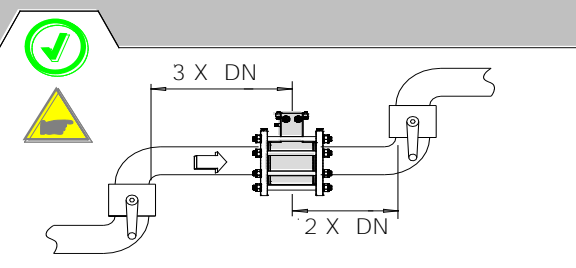

Avoid positioning flange and counter flanges by tightening the nuts.

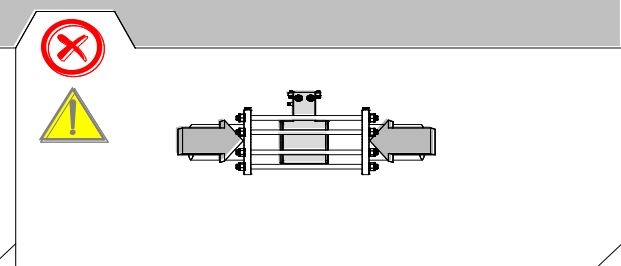
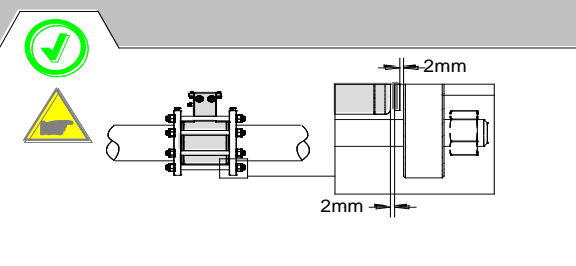

RECOMMENDED INSTALLATION METHOD

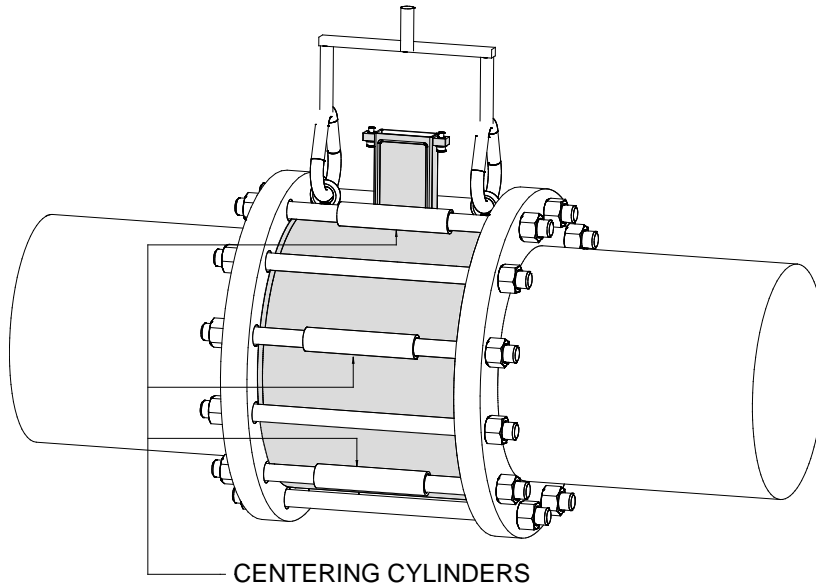

In order to help the installation the DN > 150 they are equipped with appropriate eyebolts to lift the sensor according to the above illustrated method

- The eyebolts support the only weight of the meter
- For sensor MS 1000 we recommend the use of centring cylinders

SENSOR GROUNDING

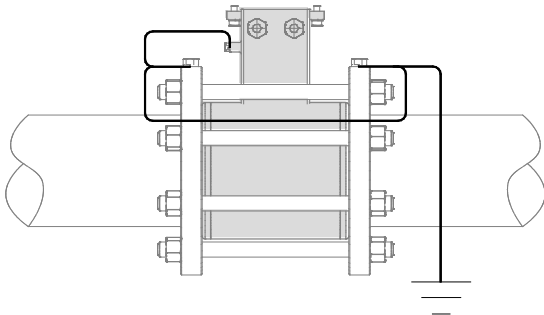
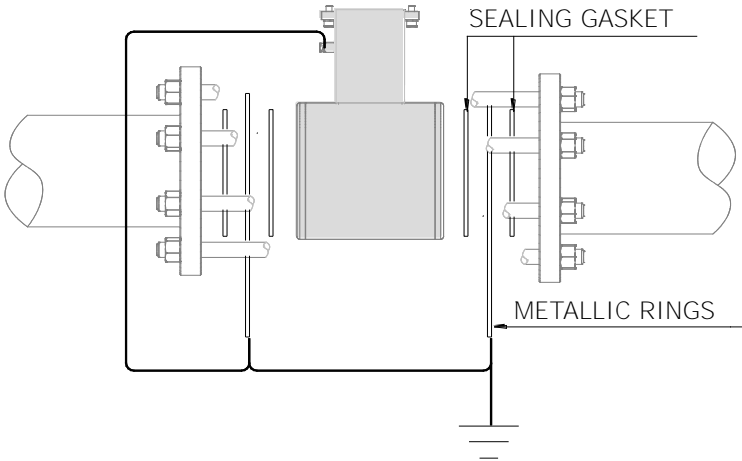
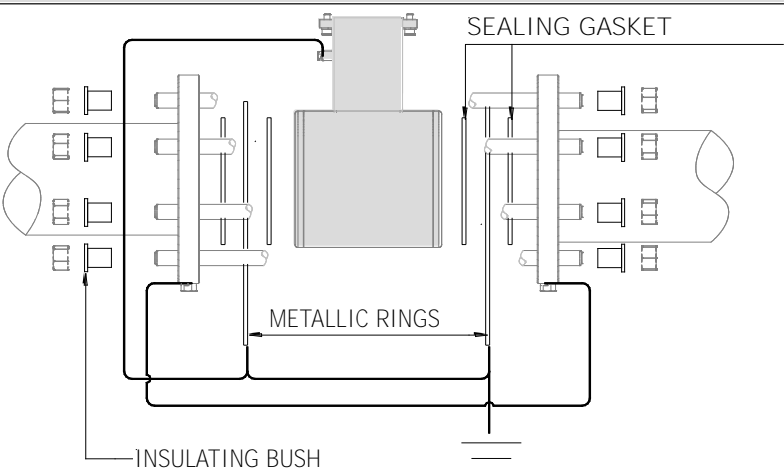
METALLIC PIPE	
	
INSULATED PIPE	
	<p>-If the sensor has to be installed in a pipe made of an insulating material, the following are necessary:</p> <ul style="list-style-type: none"> - Inserting two metallic rings between the sensor flanges and the pipe line counter flanges <p>or</p> <ul style="list-style-type: none"> - Using a sensor with the additional grounding electrode
PIPE WITH CATHODIC PROTECTION	
	<p>If the sensor has to be installed in the pipe with a cathodic protection, the following are necessary:</p> <ul style="list-style-type: none"> - using insulating bushes to isolate the bolts - Metallic grounding rings should be provided to ground the liquid using insulating gasket between the rings

SEPARATE VERSION

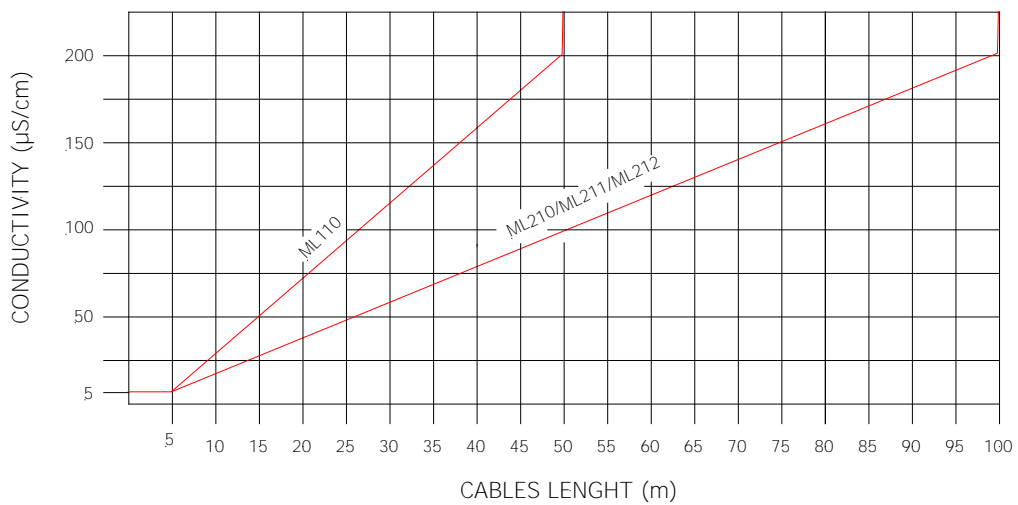
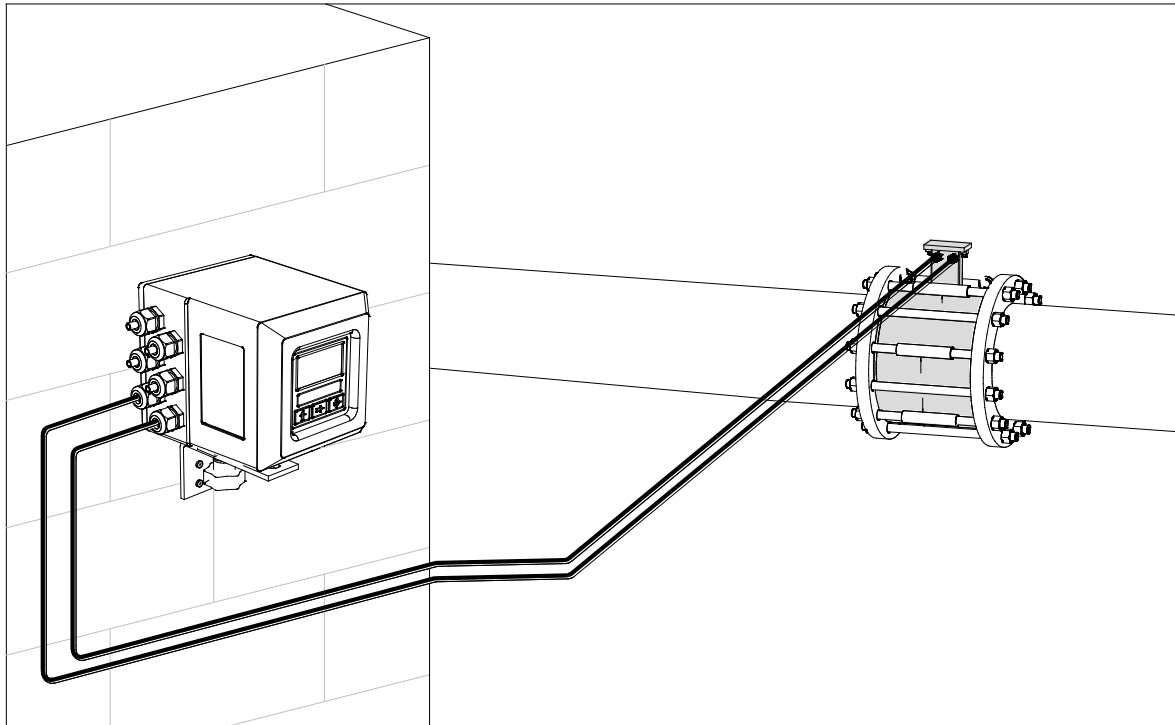
**Notes:**

- **It is recommended to install the connection cables away from, or protect against sources of electromagnetic noise.**
- **The minimum conductivity of the liquid medium to ensure correct functionality of the empty pipe detection is 20 µS/cm**

PRESSURE LOSS CALCULATION (CONES 8° ANGLES)

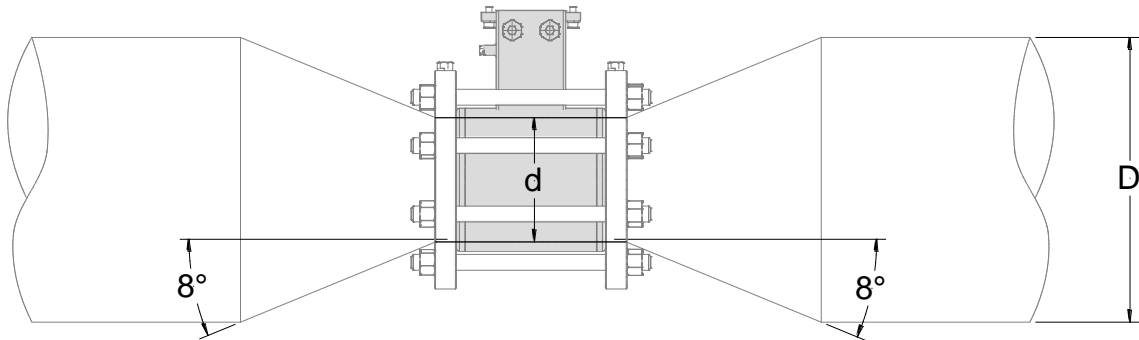

$$\Delta p = \left[0.10 + 0.20 \left(\left(\frac{d}{D} \right)^{-2} - 1 \right) \left(\frac{d}{D} \right)^4 \right] \left(\rho \frac{u^2}{2} \right)$$

Where:

Δp = Pressure loss in [Pa]

ρ = Fluid density [kg/m^3] typical value $\rho = 1000[\text{kg}/\text{m}^3]$

d = sensor diameter [m]

D = pipe diameter (greater than sensor diameter) [m]

u = Mean flow velocity in sensor diameter [m/s]

Calculation examples Δp [mbar]								
$\frac{d}{D} \backslash u$	1 [m/s]	2 [m/s]	3 [m/s]	4 [m/s]	5 [m/s]	6 [m/s]	7 [m/s]	8 [m/s]
0.5	1.1	4.3	9.6	17.0	26.6	38.3	52.1	68.0
0.6	0.9	3.6	8.2	14.6	22.7	32.7	44.6	58.2
0.7	0.8	3.0	6.8	12.2	19.0	27.4	37.2	48.6
0.8	0.6	2.5	5.7	10.1	15.7	22.7	30.9	40.3
0.9	0.5	2.1	4.8	8.6	13.4	19.3	26.3	34.3

Note :

- $\rho = 1000[\text{kg}/\text{m}^3]$ as goodness approximation of water density in common use.
- Inner diameter of sensor is used for d , express in meters.
- Indeed pressure loss equation is dimensionally correct in [Pa]. The equation results in table are show in [mbar].

HOW TO ORDER

MS1000	
EXAMPLE CODE	Diam. Nom. / Rivestimento / Temp. Massima / Campo di misura
T25	P25 DN25 (1"), Polypropilene lining, measuring range 0...0,73/0...18 m ³ /h
	T25 DN25 (1"), PTFE lining, measuring range 0...0,73/0...18 m ³ /h
	P32 DN32 (1 1/4"), Polypropilene lining, measuring range 0...1,20/0...29 m ³ /h
	T32 DN32 (1 1/4"), PTFE lining, measuring range 0...1,20/0...29 m ³ /h
	P40 DN40 (1 1/2"), Polypropilene lining, measuring range 0...1,87/0...46 m ³ /h
	T40 DN40 (1 1/2"), PTFE lining, measuring range 0...1,87/0...46 m ³ /h
	P50 DN50 (2"), Polypropilene lining, measuring range 0...2,93/0...72 m ³ /h
	T50 DN50 (2"), PTFE lining, measuring range 0...2,93/0...72 m ³ /h
	P65 DN65 (2 1/2"), Polypropilene lining, measuring range 0...4,9/0...122 m ³ /h
	T65 DN65 (2 1/2"), PTFE lining, measuring range 0...4,9/0...122 m ³ /h
	P80 DN80 (3"), Polypropilene lining, measuring range 0...7,5/0...184 m ³ /h
	T80 DN80 (3"), PTFE lining, measuring range 0...7,5/0...184 m ³ /h
	P100 DN100 (4"), Polypropilene lining, measuring range 0...11,7/0...288 m ³ /h
	T100 DN100 (4"), PTFE lining, measuring range 0...11,7/0...288 m ³ /h
	P125 DN125 (5"), Polypropilene lining, measuring range 0...18,3/0...450 m ³ /h
	T125 DN125 (5"), PTFE lining, measuring range 0...18,3/0...450 m ³ /h
	P150 DN150 (6"), Polypropilene lining, measuring range 0...26,3/0...648 m ³ /h
	T150 DN150 (6"), PTFE lining, measuring range 0...26,3/0...648 m ³ /h
	E200 DN200 (8"), Ebonite lining, measuring range 0...46,8/0...1152 m ³ /h
	T200 DN200 (8"), PTFE lining, measuring range 0...46,8/0...1152 m ³ /h
E250 DN250 (10"), Ebonite lining, measuring range 0...73,2/0...1800 m ³ /h	
E300 DN300 (12"), Ebonite lining, measuring range 0...105,4/0...2592 m ³ /h	
E350 DN350 (14"), Ebonite lining, measuring range 0...143,4/0...3528 m ³ /h	
E400 DN400 (16"), Ebonite lining, measuring range 0...187,3/0...4608 m ³ /h	
Gasket material (internal tightness - only PP lining)	
0	0 No O-Ring (ONLY FOR PTFE/EBANITE LINING)
	1 O-Ring : FKM
	2 O-Ring : Epdm
	9 Gasket material: to be specified
Body material	
A	A Body in Carbon Steel, RAL6028 painted
	B Body in Stainless Steel (AISI304)
	C Body in Stainless Steel (AISI316)
	Z Body material: other
Number and electrodes material	
1	1 n. 2 measure electrodes in AISI316
	2 n. 3 (2 measure + 1 for ground) electrodes in AISI316
	4 n. 3 (2 measure + 1 for ground) electrodes in Hastelloy C
	5 n. 3 (2 measure + 1 for ground) electrodes in Titanium
	6 n. 3 (2 measure + 1 for ground) electrodes in Tantalum; not available with Polypropilene
	7 n. 3 (2 measure + 1 for ground) electrodes in Platinum; not available with Polypropilene
	0 Electrode material: to be specified
Execution / Protection rate	
A	A Compact version , IP67 protection rate
	B Separate version , remember to add the cables , protection rate IP68 (standing immersion with 1,5 m of head water)
	E Separate version with length and position of the neck of the Sensor to define according draw. G006 (valid for A-B-C-D versions, add the relative COST)
	F Separate version with N° 2 connectors IP 68 suitable for fast cable connections
	G Separate version with N° 1 connectors IP 68 suitable for fast cable connections
	M Compact version , IP67 protection rate , with the possibility to turn the converter of 90°
	N Separate version in Aluminum , with JB PREAMPLIFIRE* (maximum len. 500 m.), remember to add the cables ,protection rate IP67
	P Separate version in AISI 304, with JB PREAMPLIFIRE* (maximum length 500 m.), remember to add the cables ,protection rate IP67
	Q Separate version with N° 1 connectors IP 68 suitable for fast cable connection to JB PREAMPLIFIRE* in Aluminum (DEFINE THE CABLE LENGHT MAX 500 m-ADD THE COST)
	R Separate version with N° 1 connectors IP 68 suitable for fast cable connections to JB PRAMPLIFIRE* IN AISI 304 (DEFINE THE CABLE LENGHT MAX 500 m-ADD THE
	X Separate version with JUNCTION BOX in AISI 304 (Rif. Dis R038)



MS1000-T25-0A1A (Complete code example for order)

Due to the constant technical development and improvements of its products, the manufacturer reserves the right to make changes and / or modify the information contained in this document without notice. Information contained herein is not binding