

KATflow G

Clamp-on Ultrasonic Flowmeter

NON-INVASIVE GAS FLOW MEASUREMENT SYSTEM

The KATflow flowmeters are well established for liquid flow applications and can now be applied for the non-invasive measurement of gases using a unique method which allows the measurement of media not just for high pressure applications but even down to atmospheric conditions. This is achieved through advances in sensor technology, powerful sophisticated

electronics and innovative signal processing algorithms using Digital Signal Processors (DSP's). Each gas flow measurement application is evaluated in order to determine the most suitable sensors, the best measurement strategy, algorithms and hardware options. Both fixed and portable solutions can be provided for safe and hazardous area use.

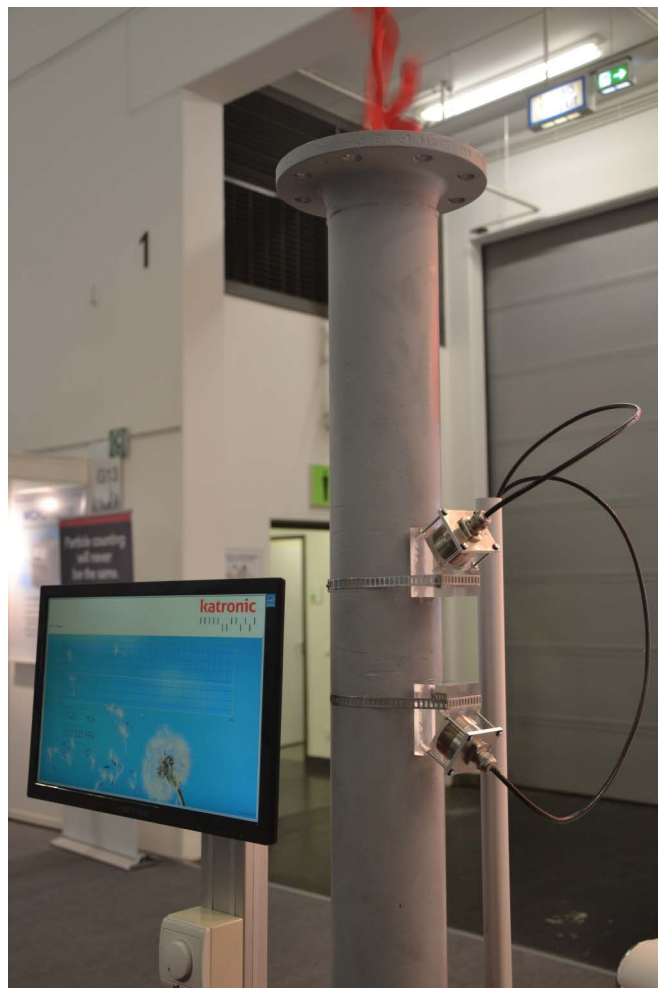

THE TECHNOLOGY BEHIND THE MEASUREMENT

The KATflow non-invasive flowmeters work on the transit time ultrasonic principle. This involves sending and receiving ultrasonic pulses from a pair of sensors and examining the time difference, phase and frequency shifts in the signal. Katronic uses clamp-on transducers that are mounted externally on the surface of the pipe and which generate pulses that pass through the pipe wall. The flowing liquid within causes interactions with the ultrasonic signals, which are then evaluated by the flowmeter to produce an accurate flow measurement.

The key principle of the method applied is that sound waves travelling with the flow will move faster than those travelling against it.

The difference in the transit time of these signals is proportional to the flow velocity of the liquid and consequently the flow rate.

Since elements such as flow profile, type of gas and pipe material will have an effect on the measurement, the flowmeter compensates for and adapts to changes in the medium in order to provide reliable results.

The KATflow Gas Flow Measurement System uses depending on the application parameters either Shear or Lamb Wave transducers to obtain an optimum Signal-to-Noise Ratio (SNR), therefore it is important that the relevant parameters are evaluated with the help of our Application Datasheet.

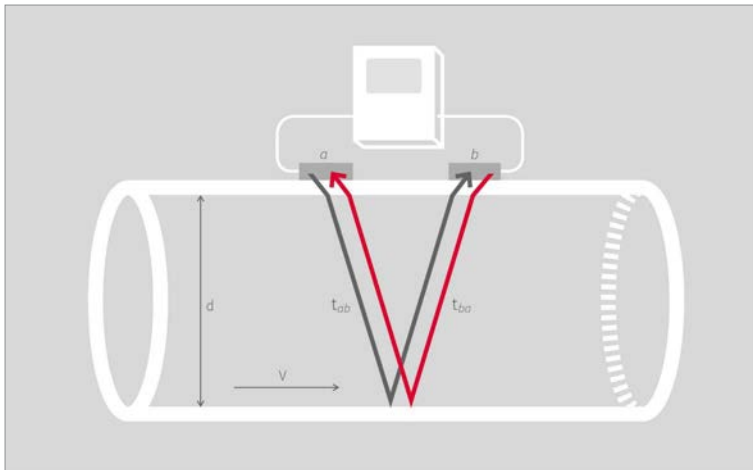

Sensors *a* and *b* work alternately to send and receive ultrasonic pulses. The sound waves *ab* travelling with the flow move faster than those travelling against it *ba*.

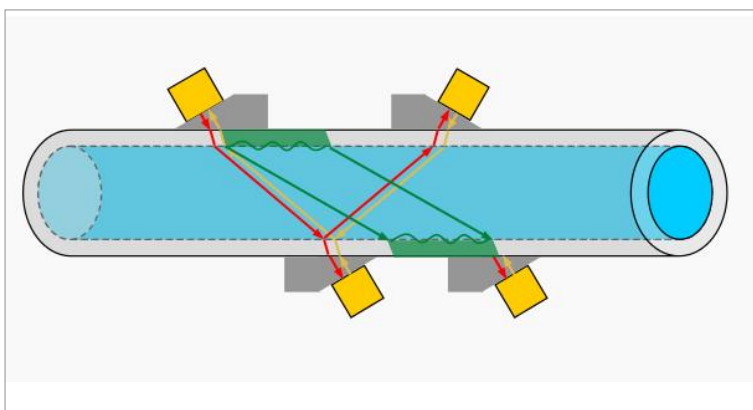

Sensor mounting arrangements for Shear Wave (red/yellow) and Lamb Wave (green) signal evaluation shown.

SPECIFICATION

- Pipe diameter range 10 mm to 1,500 mm
- Temperature range for safe area sensors
-20 °C to +135 °C, for Ex-sensors -40 °C to +80 °C
- Portable or fixed installation solutions available
- Flow velocities 0.1 m/s to 70 m/s
- All commonly used pipe materials
- Pressure range 1 bar (absolute) to unlimited maximum
- Media: Natural gas, process gas, oxygen, nitrogen, carbon monoxide, ethane, hydrogen, air, argon, helium, ethylene, propane, nitrous oxide, saturated steam

FEATURES

- Suitable for installation in safe and/or hazardous areas
- Shear and Lamb Wave IP 68 stainless steel sensors
- Process output options including current, open-collector, relay
- Communication option Modbus RTU
- Inputs for temperature, pressure and gas compressibility factor available

ACCESSORIES

- Web based data evaluation, instrument setup via wired, wireless or GSM connection

APPLICATIONS

- Measurement on natural gas pipelines
- Natural gas storage installations
- Control of compressor stations
- Measurement of ethane, propane and hydrogen
- Sour gas measurements
- Measurement of injection media
- Synthesised gas flow measurements
- Compressed air consumption measurements
- Gas dehydration



FLOWMETERING SYSTEM

Performance

Measurement principle	Ultrasonic correlation transit-time difference
Flow velocity range	0.1 ... 70 m/s
Resolution	0.25 mm/s
Repeatability	0.15 % of measured value, ± 0.015 m/s
Accuracy	Volume flow: $\pm 1 \dots 3$ % of measured value depending on application
Turn down ratio	1/200 (equivalent to 0.5 ... 70 m/s)
Measurement rate	100 Hz (standard)
Response time	1 s (standard), at start-up 3.3 s ... 10 s
Damping of displayed value	0 ... 99 s (selectable by user)
Pressure range	0.1 MPa (1 bar) to unlimited max.
Liquid content of gas	< 5 % of volume

System diagram

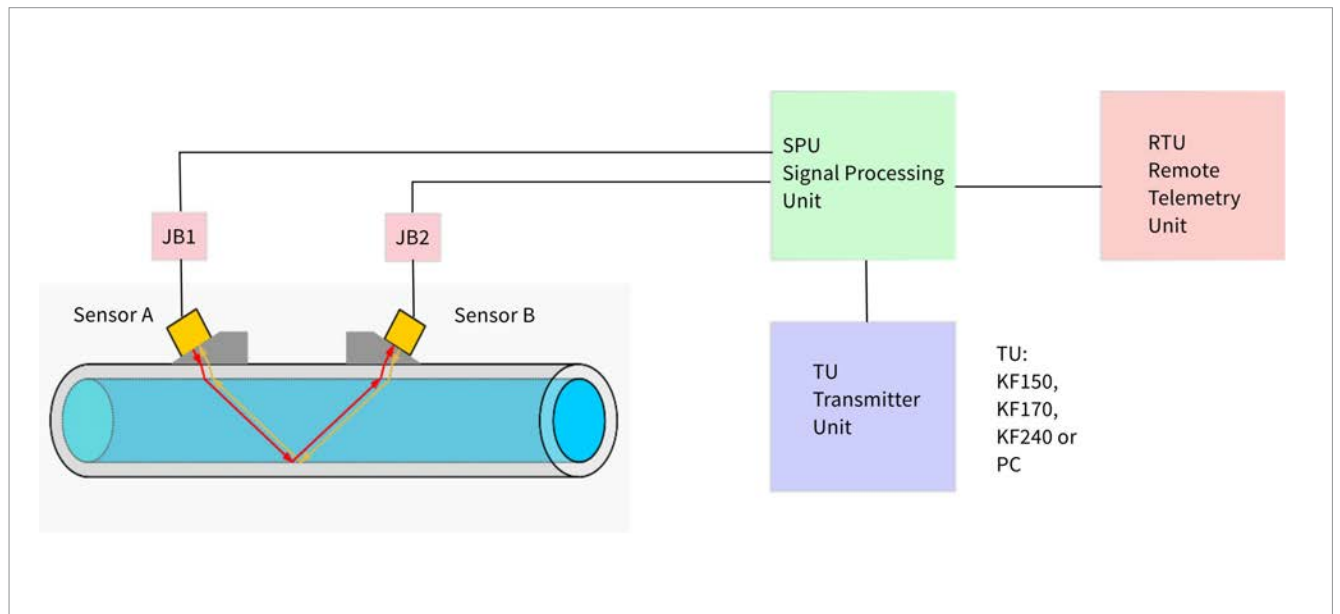

KATflow G system diagramm

General

Enclosure type	Field housing, pipe or wall mounted or portable solution
Degree of protection	IP 66 according to EN 60529
Operating temperature	-20 ... +60 °C (-4 ... +140 °F)
Housing material	Copper-free aluminium, polyurethane and epoxy-coated, stainless steel (optional), plastic portable housing
Protection concept	Flame-proof (d), increased safety (e) for fixed solutions
Ex-certification code	II 2G Ex de IIB T6
Ex-certification number	EPS 11 ATEX 1355 X
Measurement channels	1
Power supply	100 ... 240 V, AC 50/60 Hz 9 ... 36 V DC Special solutions on request
Display	LCD graphic display, 128 x 64 dots, backlit
Power consumption	< 50 W
Operating languages	English (others on request)

Images (transmitter solutions)



KATflow 240 portable solution



KATflow 150 permanent installation



KATflow 170 Ex-solution with aluminium enclosure

Communication

Process data
Remote communication

Modbus RTU
Ethernet (wired or wireless) or GSM

Process variables

Volumetric flow rate
Gas flow normalisation

Standard or normalised
AGA8 or GERG

Process inputs (galvanically isolated)

Temperature, pressure, gas composition

Process outputs (galvanically isolated)

2 off process outputs available

TRANSDUCERS

G2, G3, G5, G10, G20

Transducer type G2	200 kHz (Ex and non-Ex)
Transducer type G3	300 kHz (Ex and non-Ex)
Transducer type G5	500 kHz (Ex and non-Ex)
Transducer type G10	1 MHz (Ex and non-Ex)
Transducer type G20	2 MHz (non-Ex)
Material of sensor heads	Stainless steel
Material of wedge	PPSU
Material of cable conduits	PTFE
Temperature range	-40 ... +80 °C (for Ex-versions) -20 ... +135 °C (for non-Ex-versions)
Standard cable lengths	3.0 m
Degree of protection	IP 68 according to EN 60529
Ex-certification code	II 2G Ex mb IIC T6 Gb
Ex-certification number	ZELM 04 ATEX 0212 X
Ex-protection method	Encapsulation (m), high level of protection (b)
Note	The transducers are approved for use in hazardous areas classified as Ex-Zone 1 and 2. They are connected directly to the flowmeter or via extension cables and Ex-approved junction boxes.

MOUNTING ACCESSORIES

General

Diameter range and mounting types

Metallic clips and chains for portable us: DN 10 ... DN 1200
 Mounting frame and sensor protection: DN 50 ... DN 1500

Images

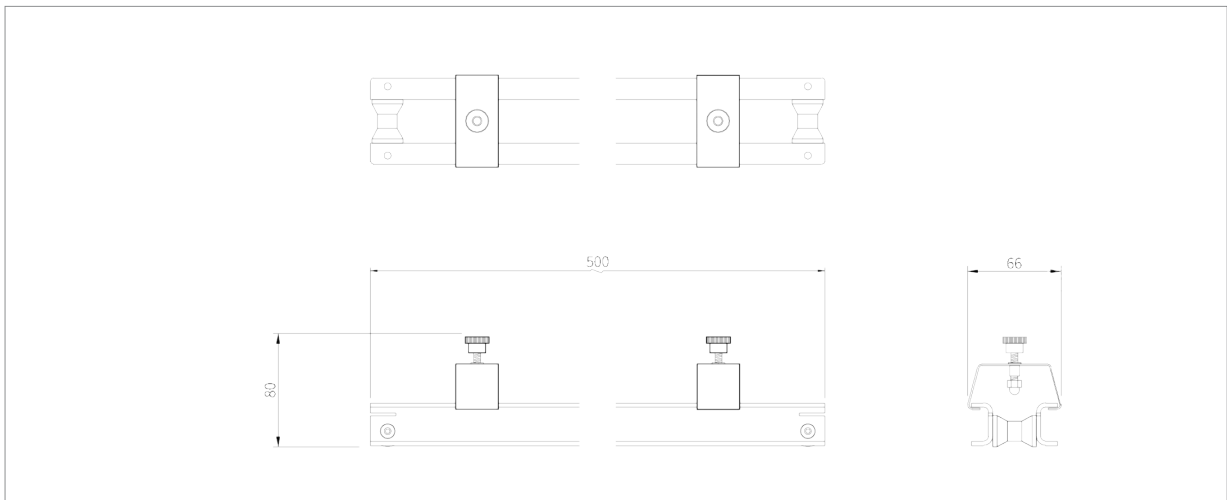

Example of metallic mounting rail



Example mounting rail with transducers

U-F-M b.v. (Official Katronic distributor for the Benelux)

Argon 3

4751 XC Oud Gastel

The Netherlands

+31 (0)165 855 655

info@u-f-m.nl

www.u-f-m.com